

**APPENDIX 4**  
**Erosion and Sediment Control**  
**Best Management Practices**

**IMPROVEMENT PLANS TO LAST CHANCE COURT  
EROSION AND SEDIMENT CONTROL BEST MANAGEMENT PRACTICES**

<b>BMP</b>	<b>HAND-BOOK #</b>	<b>DESCRIPTION AND USE</b>
<b>Wind Erosion and Dust Control</b>	EC-5	Dust control measures are to be provided during any grading or earth moving activities and for all fill piles, and unstabilized exposed soils. The application of water via a water truck is a typical dust control measure. This method typically required reapplication at a recommended rate of approximately 0.125 gal/yd <sup>2</sup> every 25 to 30 minutes. Caution must be taken to prevent water applications in excess of soil absorption rates. Otherwise, rather than preventing wind borne erosion, the excess water could result in sediment-laden runoff being deposited in unwanted areas. Dust palliatives or tackifier may be considered for any temporarily exposed area.
<b>Silt Fence</b>	SC-5	Silt fencing should be installed around the entire project site to protect the adjoining property. The longer the existing chain-lined fence can remain in place, the less maintenance will be required to maintain the integrity of the silk fence, if it is built up along the inside of the fence on the property.
<b>Stabilized Construction Entrance/Exit</b>	SC-8	A temporary stabilized construction entrance shall be installed prior to commencement of grading to prevent sediment trackout on paved roads by vehicle tires. All construction traffic entering the paved roads must cross this entrance, which could be a stabilized pad of crushed stone. Measures will control off-site sediment tracking including vehicle re-entrainment due to dust or mud from construction tires that is readily carried out of the site by vehicle travel. Off-site tracking also occurs by wet soil/mud adherence on tires, wheels, and vehicle underbodies. Construction roads should be stabilized as soon as possible after grading to reduce erosion and avoid the need for reguarding of permanent roadbeds between initial grading and final stabilization The stabilized construction entrances should be at least 50 feet long, 10 feet wide, and 3 to 6 inches deep.
<b>Storm Drain Inlet Protection</b>	DP-3	Storm drain inlet protection aids in the removal of additional sediment by increasing settling time. Gravel bags or fiber rolls are to be placed around each storm drain to filter out sediment and debris. The bags should be sufficient to prevent flow from merely routing around the bags. A drain inlet filter shall be placed in each storm drain to provide additional filtering of solids. Frequent maintenance will be required to remove accumulated sediment in and around storm drain inlets.

<b>BMP</b>	<b>HAND-BOOK #</b>	<b>DESCRIPTION AND USE</b>
<b>Stockpile Management</b>	GM-2	Stockpiled materials subject to wind erosion should be covered with plastic or other materials at the end of each construction day.
<b>Regular Street Cleaning</b>	GM-5	Soils tracked into the street will be picked up by a loader bucket and/or hand shoveled back onto the pad. Streets will also be swept on a weekly basis and more often as needed to maintain continuous litter control. All loose soil and debris shall be removed from the street areas upon starting operations and periodically thereafter as directed by the Inspector.
<b>Spill Prevention</b>	GM-6	Discharges of non-hazardous and hazardous materials can be eliminated by preventing and controlling spills. Contractors are responsible for utilizing drip pans or absorbent material under paving equipment when it is not in use, maintaining a stockpile of spill cleanup materials located where it will be readily accessible, and for immediate clean up of spills and proper disposal of soils and materials.
<b>Concrete Washout</b>	GM-9	Every construction site utilizing concrete trucks are required to have a concrete washout area in the project area.
<b>Material Delivery and Storage</b>	GM-10	It is the responsibility of the Contractor to define construction staging areas. A storage area should be designated on-site that is not near a storm drain or water course for delivery, handling, and storage of materials. Materials subject to wind blowing need to be covered with plastic at the end of each day. Materials being transported to and from the site in trucks (including fill) are subject to wind blowing, and should be covered.
<b>Paints and Liquids</b>	GM-11	A specific storage and cleaning area should be designated to minimize or eliminate paint wastes, adhesives, solvents, and cleaning products to storm drains or watercourses.
<b>Pavement Construction Management</b>	GM-12	Substances used to coat asphalt trucks shall not contain detergent and shall be non-foaming and non-toxic. Spilled oil and asphalt must be disposed of according to state, local, and federal regulations. Do not clean paving equipment on site.

# WIND EROSION AND DUST CONTROL

## EC-5

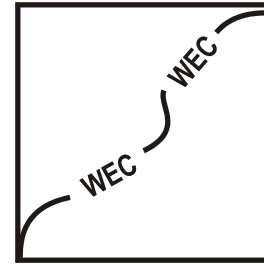
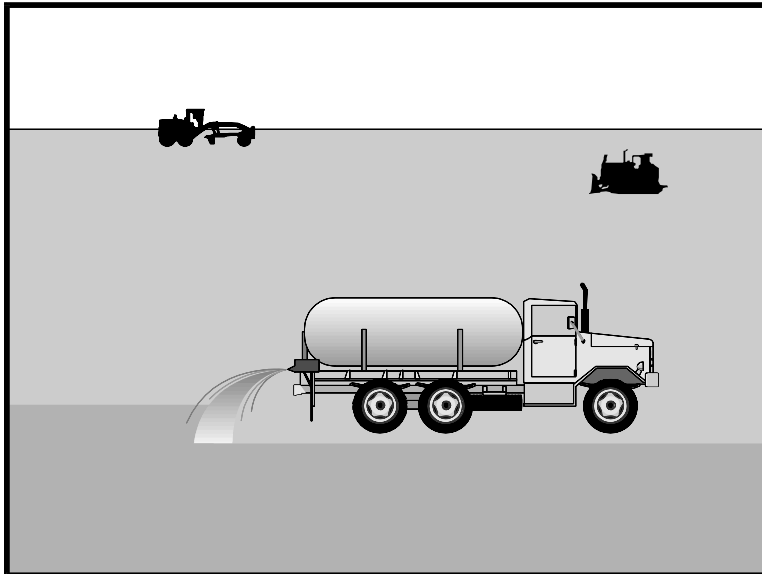

MAP SYMBOL

Graphics used with permission of Caltrans

**Purpose:** Stormwater runoff, wind, erosion, and vehicle trackout from construction sites can re-disperse sediments to the air by high winds and traffic. Therefore, the purpose of dust control is to minimize these effects.

**Application:**

- All construction sites having exposed soils should perform dust control measures.
- Wind erosion and dust control is important in arid and windy regions.
- Areas with soils of silts and clays are prone to dust.
- Dust control is a treatment between disturbance and construction or revegetation and is a temporary measure.
- Dust control methods can help to minimize pollutants in the stormdrain system, are inexpensive, and are easy to install and maintain.

**Limitations:**

- Dust control measures are only temporary and therefore require reapplication.
- Incorrect usage of chemical stabilizers can have adverse effects on water quality.
- Discharges from the site can occur if excessive water is sprinkled on the soils.
- Factors such as soil type, temperature, humidity, and wind velocity will impact the effectiveness of the dust control measures.

# WIND EROSION AND DUST CONTROL

# EC-5

## Standards and Specifications:

- Follow District Health Department standards and specifications when applying dust control measures at construction sites.
- A pressure-type distributor or a pipeline equipped with a spray system should be used to evenly distribute the water.
- A positive means to shutoff distribution equipment should be installed.
- At least one mobile unit should be available to apply water or dust palliative to the construction site.
- If non-potable water is used for dust control, all tanks, pipes, and other conveyances should be clearly marked with “NON-POTABLE WATER – DO NOT DRINK”. There should be no connection between potable and non-potable water.
- Soil binders (EC-4) may also be used for wind erosion and dust control.

### Sprinkling/Irrigation

- Moistening road surfaces is an effective dust control method for traffic routes.
- This technique can be applied to all sites but lasts less than 1 day so it must be reapplied often.
- Apply 0.03 – 0.3 gal/yd<sup>2</sup> uniformly to pre-wet the soil surface.
- Apply 0.125 gal/yd<sup>2</sup> every 20-30 minutes.
- Reactivate chemicals in dry climates by rewetting with 0.1 – 0.2 gal/yd<sup>2</sup>.
- Avoid ponding by crowning the soil surface.
- Compact soils if necessary.

### Tillage

- Turning the soil brings clods to the surface where they can act to keep down the dust.

Other techniques used to control and minimize dust include the addition of vegetative covers, mulch, stones, or soil binders.

## Inspection and Maintenance:

- Daily inspections should occur for areas experiencing excessive winds, vehicle traffic, or rains.

## SILT FENCES

## SC-5

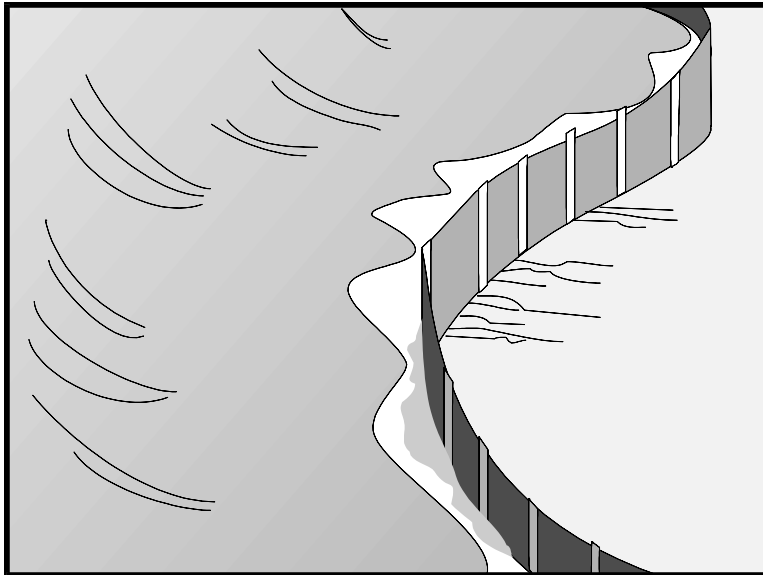

Graphics used with permission of Caltrans

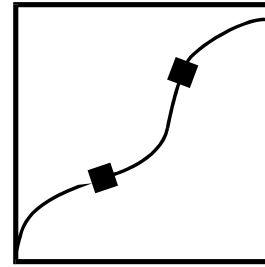

MAP SYMBOL

**Purpose:** To slow and detain sediment laden sheet flow from disturbed areas and to allow settlement of sediment prior to discharge to storm drains, streams or other watercourses.

**Application:**

- Along the construction site perimeter.
- Below the toe of slopes.
- Along streambanks and channels.
- Around temporary stockpiles.

**Limitations:**

- Not effective unless properly installed.
- Do not use on slopes greater than 4H:1V.
- Labor-intensive maintenance may be required.
- Fencing must be removed and disposed of properly upon completion of construction.

# SILT FENCES

# SC-5

## Standards and Specifications:

- Do not install silt fences across streams, channels, or in any location where flows may be concentrated.
- Fencing must be located where waters may temporarily pond and sediments can be deposited.
- Application in environmentally sensitive areas requires additional practices.
- Install the fencing along a level contour at the toe of a slope.
- Install fencing a minimum of 3 feet from the toe of the slope or at the top of the bank.
- Limit drainage area upstream of fence to 0.25 acre/100 feet of fence.
- The length of slope draining to any point along the silt fence should be less than 100 feet.
- Maximum length of any single run of fencing should be 500 feet.
- The last 8 feet of fence should be angled upslope in a “J” or “L” shape to allow for ponding.
- Silt fence material shall be woven nylon reinforced polypropylene with a built in top chord running along the top of the fabric.
- Minimum requirements of fabric are: tensile strength (ASTM D4632) of 90 lbs, puncture rating (ASTM D4833) of 60 lbs, and mullen burst rating (ASTM D3786) of 280 psi.
- Fence posts should be free from decay, splits, or cracks, have a minimum thickness of 2 inches, have a minimum length of 4 feet, should be installed a minimum distance of 12 inches into the ground, and should have a maximum spacing of 8 feet.
- Steel fence posts may also be used.
- Areas prone to high winds will require closer spacing of fence posts.
- Fence posts shall be located on the downstream side of the fabric and mesh.
- Fabric must be stapled or wired to the posts.
- Locate a 6-inch X 6-inch trench on the upstream side of the fence. Overlap at least 6 inches of fabric into the trench. Key in the bottom of the fence as shown in Detail A. Fill the trench with tamped native soil or washed gravel.

# SILT FENCES

# SC-5

- Silt fence fabric sizing:
  - If less than 50 percent of the soil by weight will pass through a U.S. Standard Sieve no. 200, select the equivalent opening size (EOS) to retain 85 percent of the soil. The EOS should not be finer than U.S. Standard Sieve no. 70.
  - For all other soils, the EOS should not be finer than U.S. Standard Sieve no. 70 except where discharge to streams or wetlands occurs. In that case, the EOS shall not be larger than U.S. Standard Sieve no. 100.
  - If 85 percent of the soil by weight is finer than U.S. Standard Sieve no. 200, then filter fabric should not be used.

## **Inspection and Maintenance:**

- Inspect before and after each rain event.
- Repair any damage caused by construction (undercutting of the fence, split, torn, and weathered fabrics, or slumping of the fence).
- Fabrics may have to be replaced every 5-8 months.
- Remove silt when the depth of the deposit reaches one-third the fence height.
- Remove silt and dispose of to avoid siltation problems.
- From May through October, water should not be allowed to pond behind silt fences for more than 7 days.
- Remove fencing at the completion of the construction project or when the site has been stabilized.
- Backfill any holes or depressions caused by the removal of the silt fence according to standard specifications.

# SILT FENCES

# SC-5

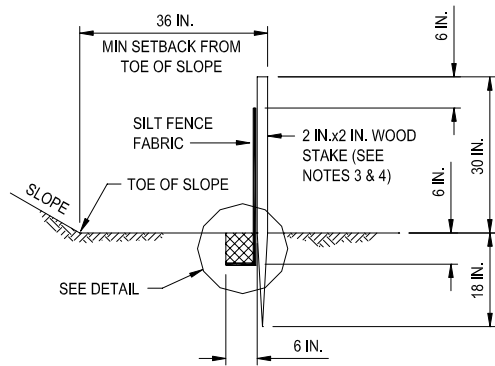

**SECTION A-A**

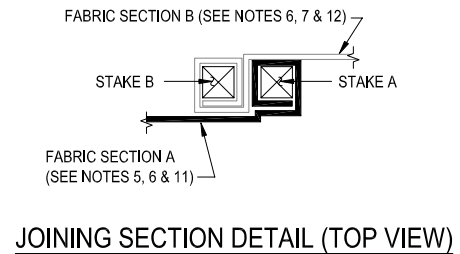

**JOINING SECTION DETAIL (TOP VIEW)**

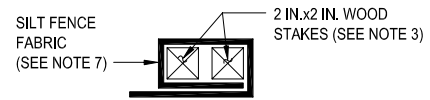

**END STAKE DETAIL (TOP VIEW)**

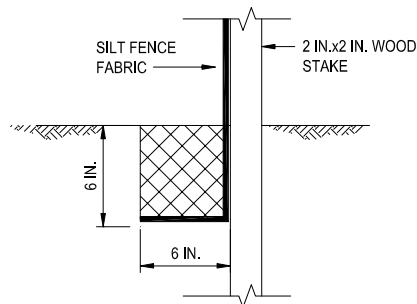

**DETAIL A**

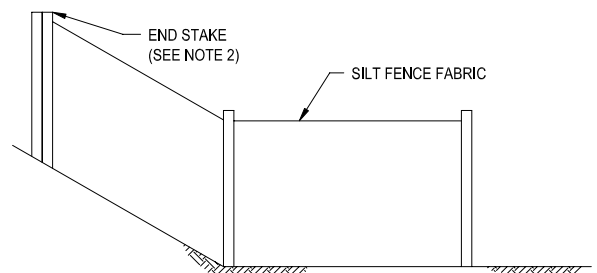

**ELEVATION  
END DETAIL**

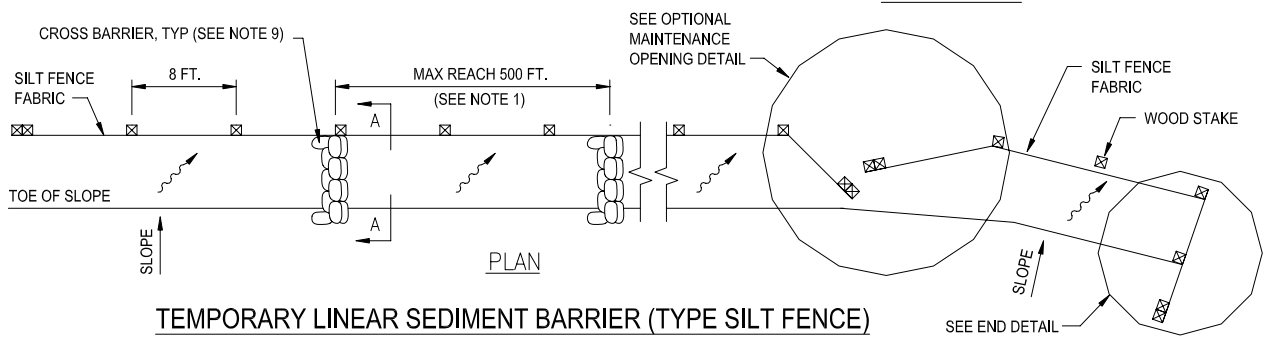

**TEMPORARY LINEAR SEDIMENT BARRIER (TYPE SILT FENCE)**  
NOT TO SCALE (ADAPTED FROM CALTRANS)

# SILT FENCES

# SC-5

## TEMPORARY LINEAR SEDIMENT BARRIER (TYPE SILT FENCE)



NOT TO SCALE

(ADAPTED FROM CALTRANS)

### NOTES

1. CONSTRUCT THE LENGTH OF EACH REACH ALONG CONTOURS SO THAT THE CHANGE IN BASE ELEVATION ALONG THE REACH DOES NOT EXCEED 1/3 THE HEIGHT OF THE LINEAR BARRIER. IN NO CASE SHALL THE REACH LENGTH EXCEED 500 FEET.
2. THE LAST 8 FEET OF FENCE SHALL BE TURNED UP SLOPE.
3. STAKE DIMENSIONS ARE NOMINAL. STEEL STAKES ARE ALSO ACCEPTABLE.
4. STAKES SHALL BE SPACED AT 8 FEET MAXIMUM INTERVALS AND SHALL BE POSITIONED ON DOWNSTREAM SIDE OF FENCE.
5. STAKES TO OVERLAP AND FENCE FABRIC TO FOLD AROUND EACH STAKE ONE FULL TURN. SECURE FABRIC TO STAKE WITH AT LEAST 4 STAPLES.
6. STAKES SHALL BE DRIVEN TIGHTLY TOGETHER TO PREVENT POTENTIAL FLOW-THROUGH OF SEDIMENT AT JOINT. THE TOPS OF THE STAKES SHALL BE SECURED WITH WIRE.
7. FOR END STAKE, FENCE FABRIC SHALL BE FOLDED AROUND TWO STAKES ONE FULL TURN AND SECURED WITH AT LEAST 4 STAPLES.
8. MINIMUM 4 STAPLES PER STAKE. DIMENSIONS SHOWN ARE TYPICAL.
9. CROSS BARRIERS SHALL BE A MINIMUM OF 1/3 AND A MAXIMUM OF 1/2 THE HEIGHT OF THE LINEAR BARRIER.
10. MAINTENANCE OPENINGS SHALL BE CONSTRUCTED IN A MANNER TO ENSURE SEDIMENT REMAINS BEHIND SILT FENCE.
11. JOINING SECTIONS SHALL NOT BE PLACED AT SUMP LOCATIONS.
12. SANDBAG ROWS AND LAYERS SHALL BE OFFSET TO ELIMINATE GAPS.

### LEGEND

-  TAMPED BACKFILL
-  SLOPE DIRECTION
-  DIRECTION OF FLOW

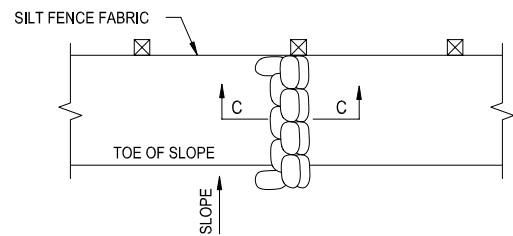

### CROSS BARRIER DETAIL

(SEE NOTE 10)

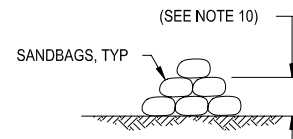

### SECTION C-C

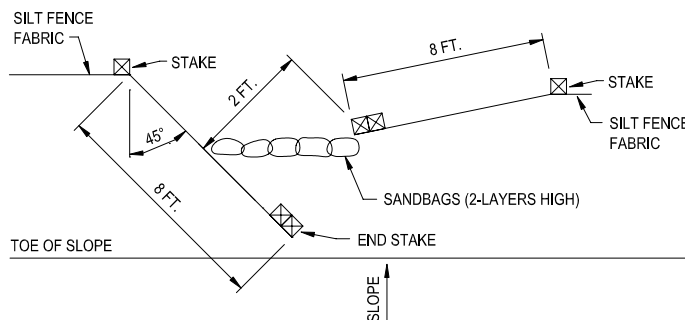

### OPTIONAL MAINTENANCE OPENING DETAIL

(SEE NOTE 10)

# SEDIMENT RETENTION BASINS

# SC-7

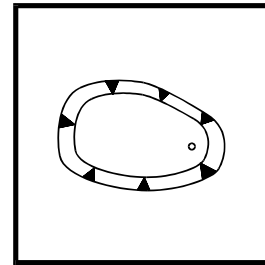
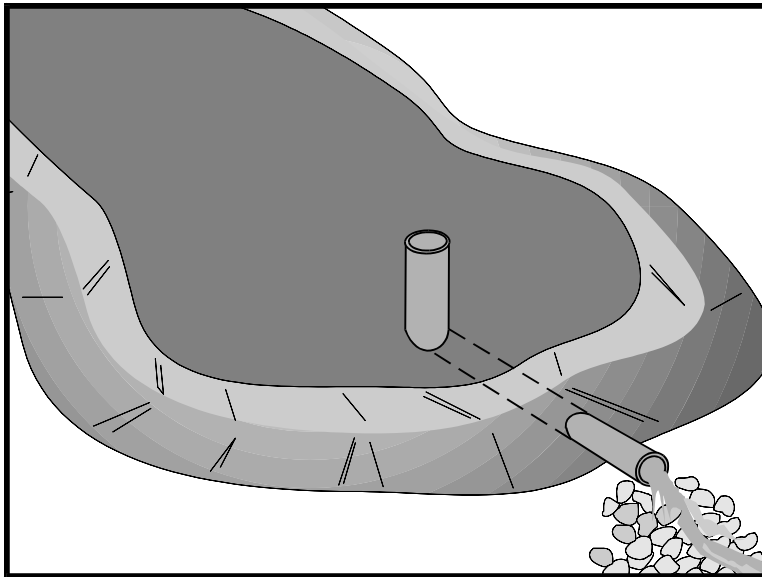

MAP SYMBOL

Graphics used with permission of Caltrans

**Purpose:** To detain sediment-laden flows and allow for settling of suspended sediments prior to discharge to storm drains, streams or other watercourses. These devices can be constructed as temporary controls that will be abandoned prior to the completion of site development or as permanent flood control and stormwater quality enhancement structures.

**Application:**

- Construction sites with disturbed areas during the wet season.
- At outlets of disturbed areas of 1 to 20 acres.
- Allows for prevention of sediment-laden stormwater from entering streams or watercourses.
- Intended for surface water only. Groundwater dewatering should not be discharged to the basin.

**Limitations:**

- Must be designed by a Nevada Registered Professional Engineer.
- Must use in conjunction with other methods to limit sediment.
- For temporary basins, maximum drainage area is 20 acres.
- Requires a large surface area to construct. Size may be limited because of site constraints.
- Site can be attractive and dangerous to small children.
- May require fencing.

# SEDIMENT RETENTION BASINS

# SC-7

- Not to be located in live streams.
- From May through October, may pose a mosquito/midge problem if water pools longer than 7 days.
- Multiple basins may be needed for large sites.
- Requires regular maintenance to remove accumulated sediments.

## Standards and Specifications:

- Permanent sediment retention basins shall be designed to local design standards.
- A Nevada Registered Professional Engineer must design and stamp all sediment retention basin plans.
- Design and construct basin prior to grading or stripping the site.
- The size of the basin can be reduced by limiting the contributing area to only runoff from the disturbed soil areas if temporary controls are used to divert runoff from upstream undisturbed or stabilized areas away from the drainage area of the sediment retention basin.
- Construct basin prior to the onset of the rainy/wet season.
- Locate the trap at a low point where failure will not cause property damage, extensive erosion or loss of life.
- Maintain an access for maintenance and equipment vehicles.
- Areas under embankments, structures and sediment traps should be cleared and stripped of vegetation.
- Capacity of temporary sediment retention basins should be designed to detain at a minimum, the calculated volume of runoff from the 2-year, 24-hour storm or 3,600 cubic feet of storage per acre of drainage area.
- See Section 5.4 regarding sizing permanent sediment retention basins.
- Use a forebay located upstream of the basin to trap larger particles and dissipate the energy of incoming flows.
- Outlet shall consist of a perforated riser pipe with perforations extending to ground level such that the basin completely drains over time.
- Design the perforations in the outlet to provide a minimum 24-hour drain time. Drain times up to 72 hours will increase sediment removal efficiencies.
- Locate the inlet and outlet to maximize the travel time. The length of the basin shall be more than twice the width of the basin. The length shall be determined by measuring the distance between the inlet and the outlet.

# SEDIMENT RETENTION BASINS

# SC-7

- If this ratio cannot be met, silt fence baffles can be added to increase the flow length.
- Each basin must have an emergency overflow spillway designed to local drainage design standards.
- Outlets, inlets and spillways should be protected with non-erodible riprap.
- Above grade embankments shall be composed of compacted fill designed to local drainage design standards.. Side slopes shall not be steeper than 3H:1V.
- Fence the area to prevent unauthorized entry where necessary.
- Remove sediments when the thickness of the deposit is 1 foot or one-third the basin volume or becomes vegetated.
- Alternative detailed designs for sediment basins will be presented in the new Structural Controls chapter that will be developed in 2003.

## **Inspection and Maintenance:**

- Inspect before and after each rain event and weekly during the wet season.
- Perform daily inspections during an extended precipitation event.
- Inspect banks for seepage or damage.
- Repair any damages caused by construction or erosion.
- Check outlet structure and spillway for damages or obstructions. Repair as needed.
- Monitor inlet and outlet to determine effectiveness. Make corrections to the basin if it is not performing properly.
- Remove silt when the depth reaches one-third the basin volume and becomes vegetated.
- Remove silt and dispose of to avoid siltation problems.
- Fill in temporary basins once construction activities are complete and final stabilization has been established.
- From May through October, water should not be allowed to pond in sediment retention basins for more than 7 days

# SEDIMENT RETENTION BASINS

# SC-7

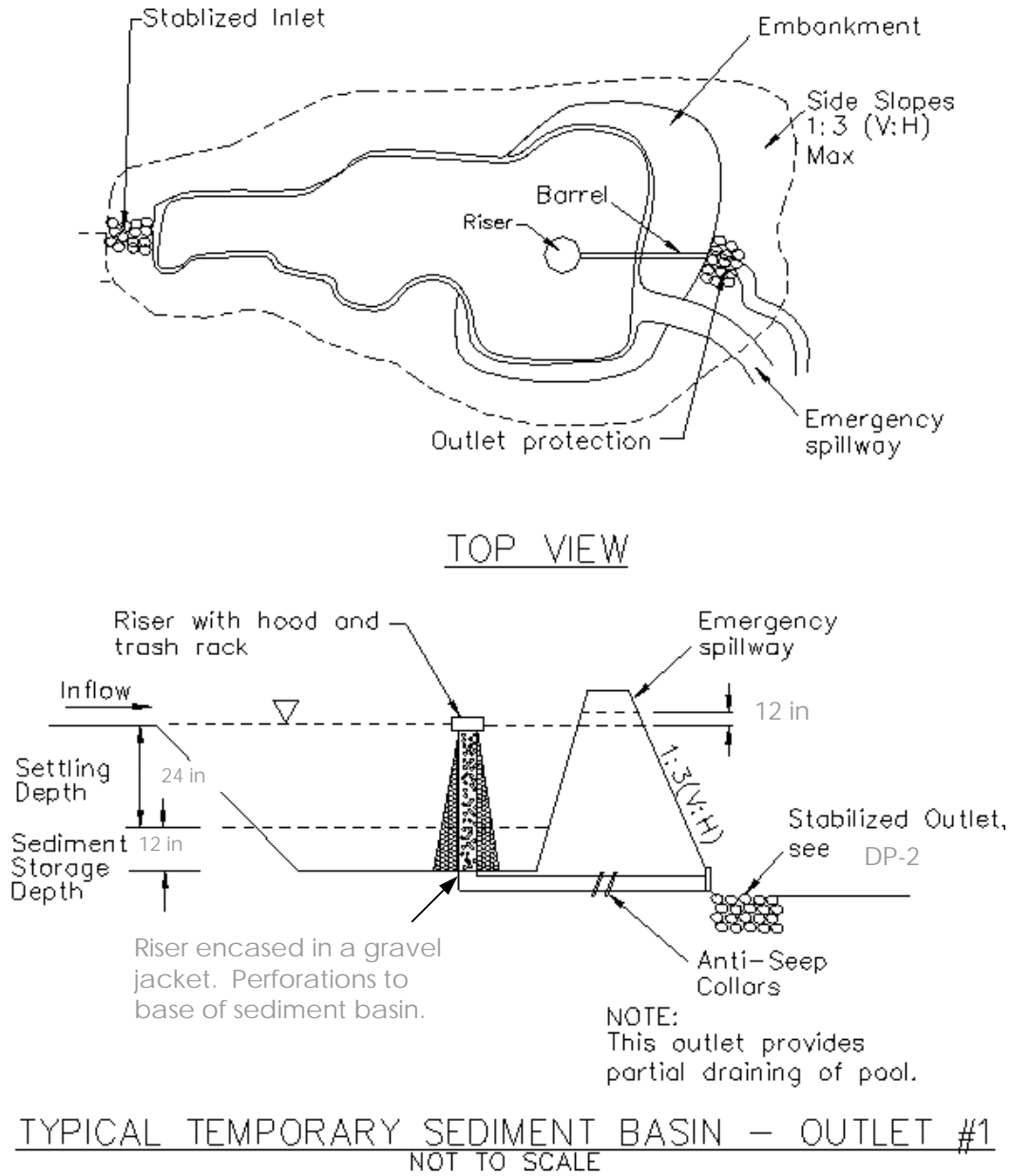

Graphic used with permission of Caltrans.

# SEDIMENT RETENTION BASINS

# SC-7

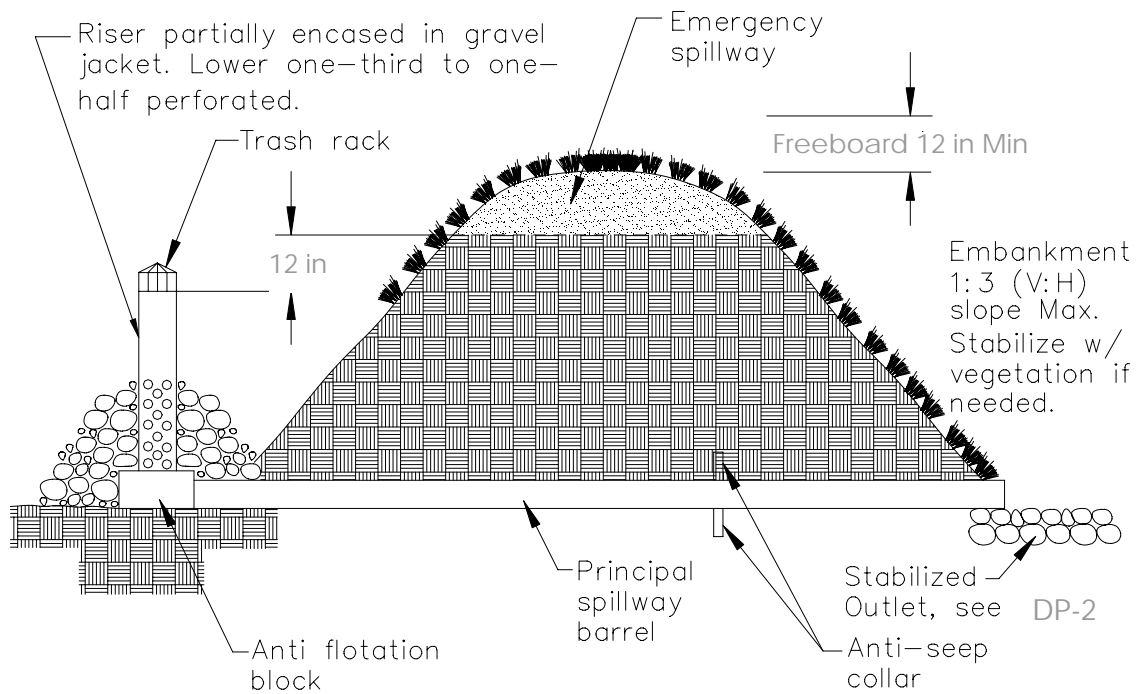

NOTE:  
This outlet provides complete draining of pool.

TYPICAL TEMPORARY SEDIMENT BASIN – OUTLET #2  
NOT TO SCALE

Graphic used with permission of Caltrans.

# CONSTRUCTION SITE ENTRANCES AND EXITS SC-8

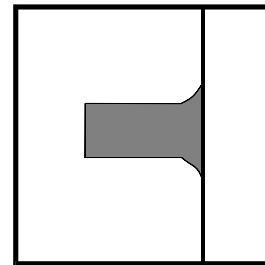
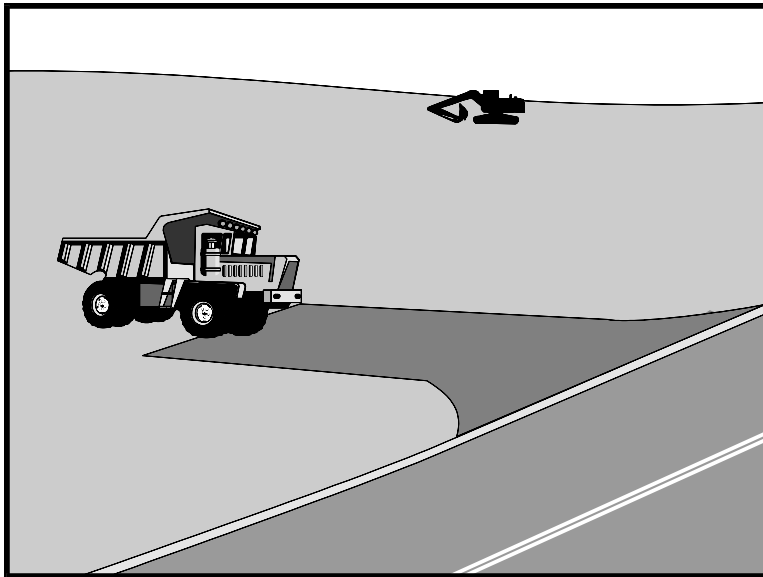

MAP SYMBOL

Graphics used with permission of Caltrans

**Purpose:** To limit the tracking of mud and dirt onto public roads by construction vehicles and to limit the spread of air borne dust.

**Application:**

- On construction sites where tracking dirt onto public roads is a potential problem.
- Outlets from disturbed areas.
- Near water crossings.
- Where poor soil conditions may cause sediments to adhere to vehicle tires.
- To control dust in trafficked areas.
- Most effective when used in conjunction with wash stations.

**Limitations:**

- Site conditions and layout will determine the design.
- Can be expensive to install and maintain.

# CONSTRUCTION SITE ENTRANCES AND EXITS **SC-8**

## **Standards and Specifications:**

- Follow all applicable District Health dust control standards.
- Grade the exits and entrances to prevent runoff from leaving the site.
- Stabilized entrances and exits should have sediment traps associated with them. Maintain the sediment traps so that there is enough space for the sediment to settle out.
- Design entrances and exits for the heaviest vehicle using the site.
- Entrance and exits can be constructed of aggregate over geotextile, concrete or asphaltic concrete based on-site conditions and longevity.
- The construction site access should be constructed of 1-3 inch washed, well-graded gravels or crushed rock. A minimum thickness of 12 inches should be applied. However, the type of material and total depth of the aggregate should be determined by a soils engineer.
- Geotextiles may be used as a filter to prevent soils under the aggregate from migrating into the aggregate.
- Minimum entrance or exit length is 50 feet.
- Minimum entrance or exit width is 10 feet.
- Provide turning radiuses where entrances or exits intersect a public way.
- Provide stop signs or other warning signs prior to leaving the site.

## **Inspection and Maintenance:**

- Perform routine inspections and repair as needed.
- Require all vehicle traffic to enter and exit at these locations only.
- Service sediment traps regularly.
- Sediments deposited on paved roadways should be removed daily and disposed of properly.
- All temporary roadway ditches should be kept clear and should be graded to prevent ponding.

# CONSTRUCTION SITE ENTRANCES AND EXITS SC-8

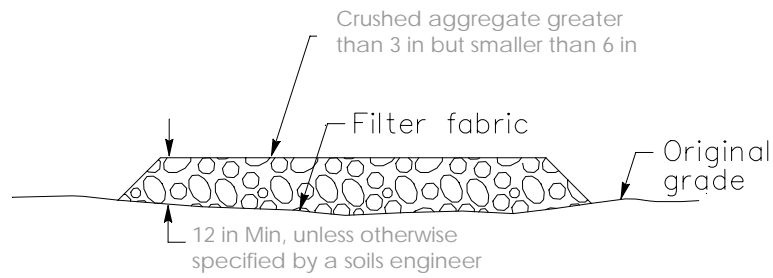

SECTION B-B  
NTS

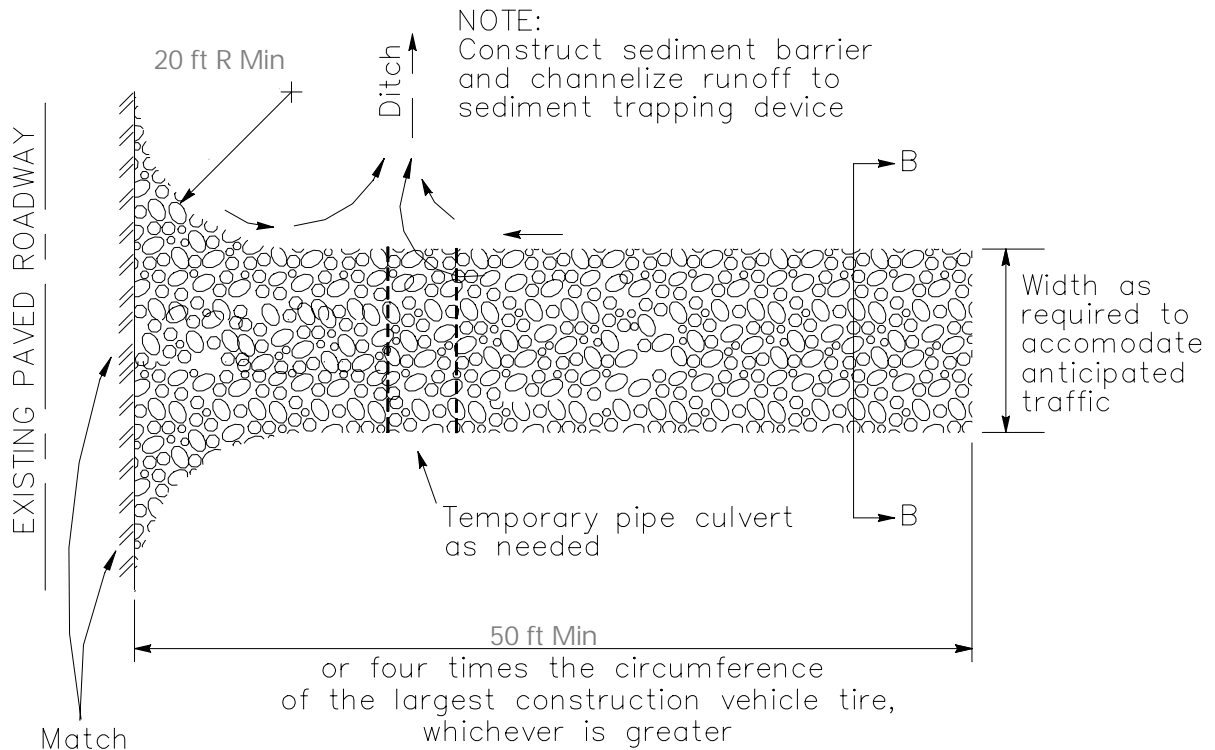

PLAN  
NTS

Graphic used with permission of Caltrans.

# CONSTRUCTION SITE ENTRANCES AND EXITS SC-8

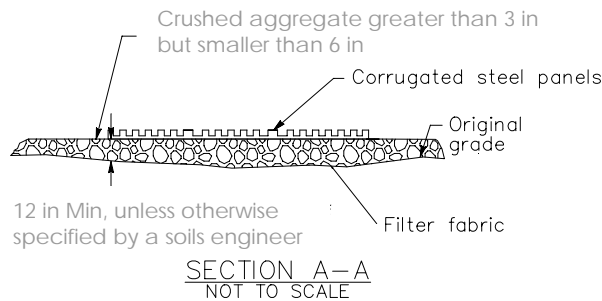
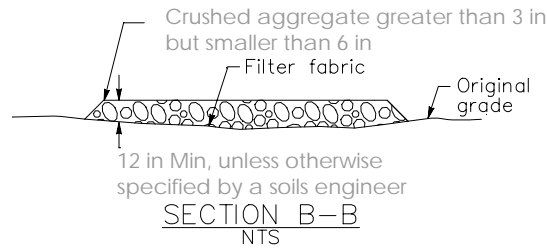

NOTE:  
Construct sediment barrier and channelize runoff to sediment trapping device

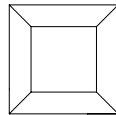

Sediment trapping device (see SC-6)

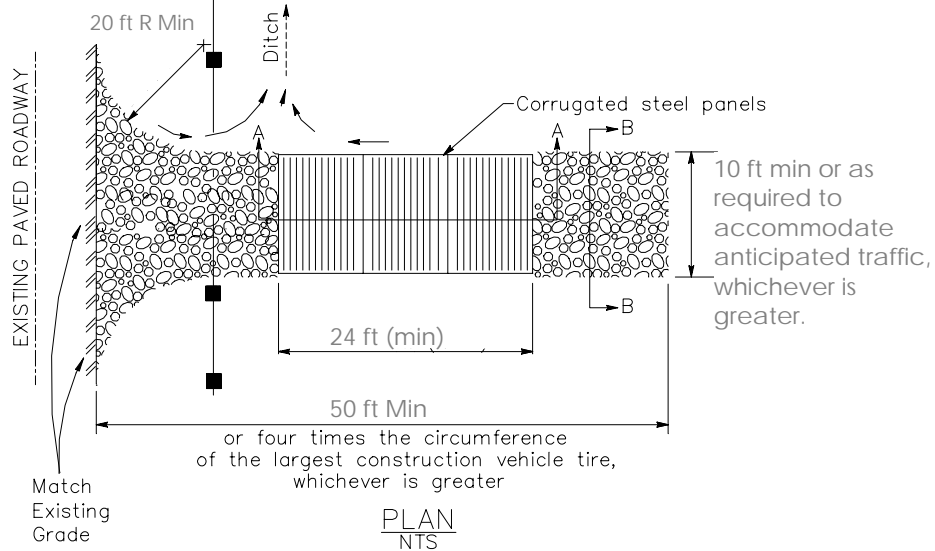

Graphic used with permission of Caltrans.

# CONSTRUCTION EXIT TIRE WASH

# SC-9

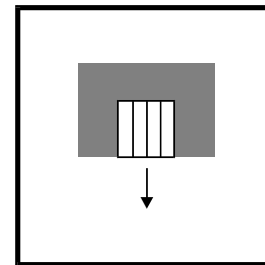
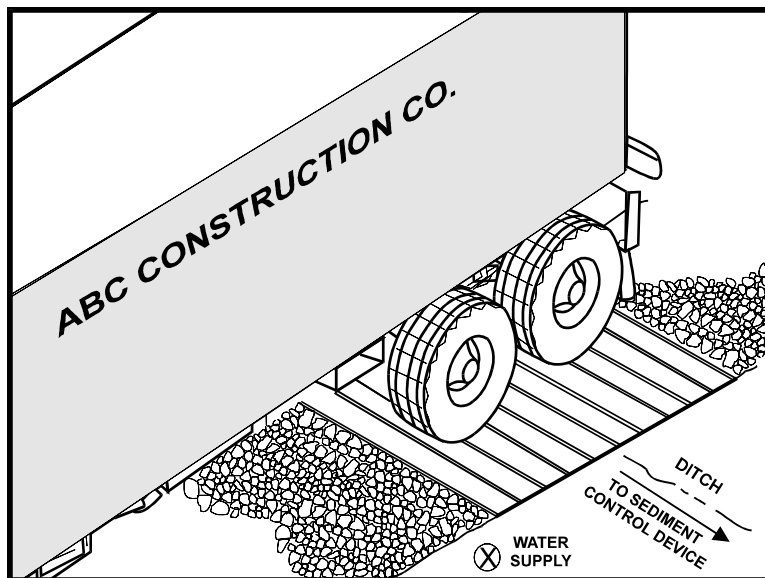

MAP SYMBOL

Graphics used with permission of Caltrans

**Purpose:** To minimize the tracking of mud and dirt onto hard surfaced public roads by construction vehicle tires.

**Application:**

- On construction sites where tracking onto public roads is a problem.

**Limitations:**

- Requires a source of wash water for the tire bath or pressure washing.
- Requires a double width entrance/exit to allow entering vehicles to avoid passing through the tire wash area.

**Standards and Specifications:**

- Use with a stabilized entrance/exit and sediment trap.
- Construct the tire wash on a level pad of coarse (3-6 inch) aggregate.
- Design, construct and manufacture the system for anticipated traffic loads.
- Minimize the depth of water in the sump to prevent damage to truck hubs and trailer tongues (12-14 inches).
- The slope of the sump should be between 6-12 inches over a 10 ft width to allow sediments to flow to the low side and to prevent resuspension of the sediments.

# CONSTRUCTION EXIT TIRE WASH

# SC-9

- A drainage ditch carrying runoff from the wash area to a sediment sump device should be provided.
- When pressure washing is applied on-site, a grate over a sump may be used.

## **Inspection and Maintenance:**

- Perform regular inspections to ensure that sediments are not tracked off site and that the wash area is functioning properly.
- Repair the tire wash as needed.
- Remove sediment accumulations from the wash rack or sediment sump.
- Waste or wash water should be collected by an on-site treatment system or disposed of properly (not into the stormdrain system).

# CONSTRUCTION EXIT TIRE WASH

# SC-9

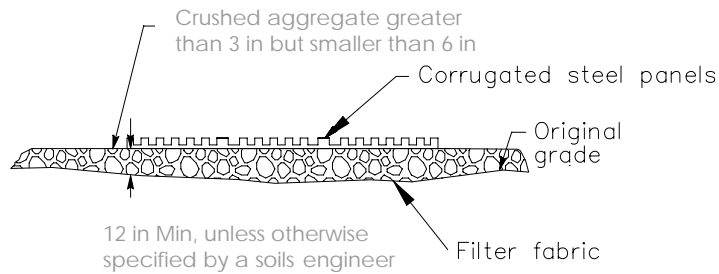

SECTION A-A  
NOT TO SCALE

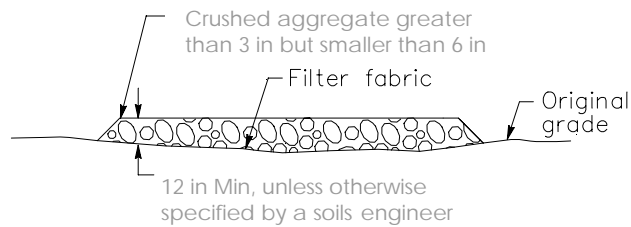

SECTION B-B  
NTS

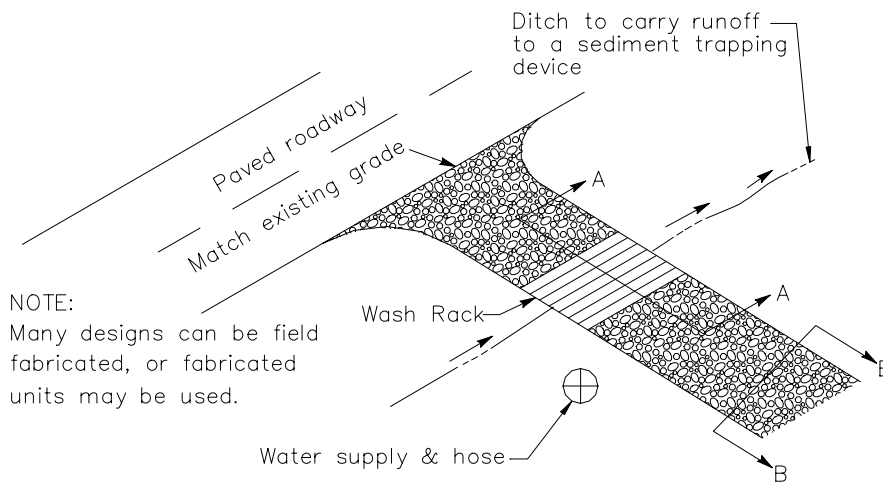

NOTE:  
Many designs can be field fabricated, or fabricated units may be used.

TYPICAL TIRE WASH  
NOT TO SCALE

Graphic used with permission of Caltrans.

# STORMDRAIN INLET PROTECTION

# DP-3

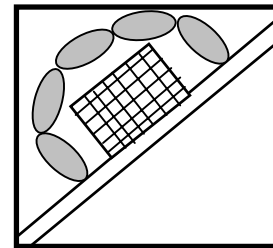
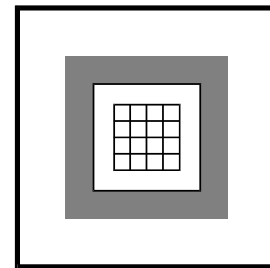
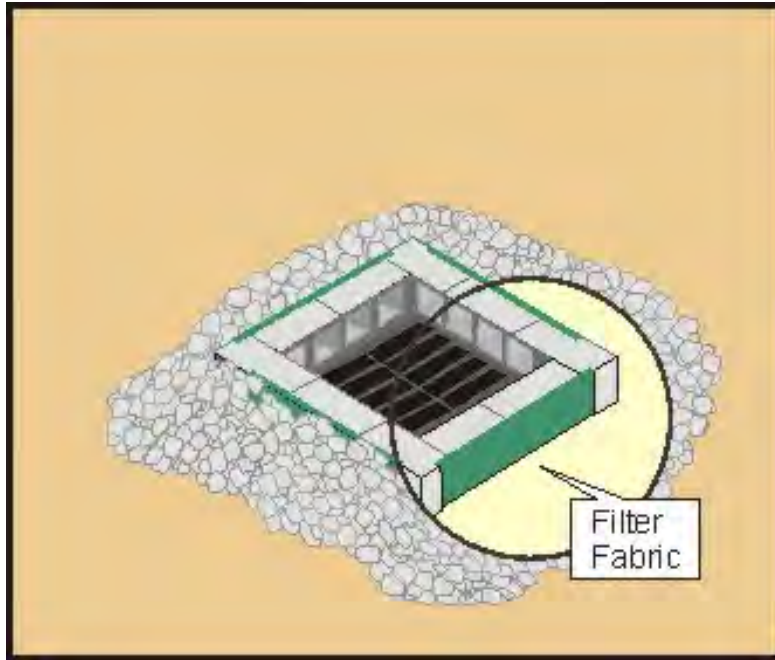

**MAP SYMBOLS**

Graphics produced by Kennedy/Jenks Consultants

**Purpose:** To allow ponding and filtering of sediment-laden runoff prior to entering the storm drain system.

**Application:**

- Inlets potentially impacted by sediment laden surface runoff.
- Drainage areas 1 acre or less.
- Disturbed drainage areas that have not been permanently stabilized.
- Applicable for wet and snowmelt seasons.
- May not be necessary if stormdrain discharges to a sediment retention basin.

**Limitations:**

- Not to be used when ponding will encroach into roadway traffic or onto erodible surfaces and slopes.
- Stormwater will bypass protected curb inlets and continue downgrade on sloped surfaces.
- Sediment removal is minimal in high flow conditions.
- Frequent maintenance is required to remove sediment and debris.
- Runoff should be routed to a sediment-trapping device if the drainage area is greater than 1 acre.
- The inlet grate should not be covered with filter fabric.

# STORMDRAIN INLET PROTECTION

# DP-3

## Standards and Specifications:

### Block and Gravel DI Protection

- Appropriate for drainage areas 1 acre and less with flows not exceeding 0.5 cfs.
- Allow for overtopping to prevent flooding.
- Place concrete blocks around inlet grate with openings parallel to the ground surface.
- Place filter fabric or wire screen around the outer openings and secure in place.
- Cover fabric or screen with 1 to 2-inch clean gravel approximately 1 foot wide.

### Filter Fabric Fence (DI Protection Type 1)

- Appropriate for relatively small (less than 1 acre), flat (less than 5 percent slope) drainage areas subject to sheet flow and for flows not exceeding 0.5 cfs.
- Only surround inlet with filter fabric fence when it is located in a sump and the top of the fence is below the top of the surrounding slopes.
- Not appropriate for paved areas.
- Filter fabrics should not be placed underneath the inlet grate.
- Stakes should be driven a minimum of 8 inches into the ground. They should be spaced a maximum of 3 feet and have a minimum dimension of 2 inches by 2 inches.
- The fabric filter should be buried at least 1 foot below the soil surface and rise no higher than 2 feet above the ground surface.
- The fabric should be cleaned or replaced when it becomes clogged with sediment.
- The sediments should be removed when the accumulation behind the fabric fence reaches one-third the height of the barrier.

### Sandbag Barrier (for Inlets on Grade)

- Sandbag barriers for inlet protection are applicable when sheet flows or concentrated flows exceed 0.5 cfs and when it becomes necessary to allow for overtopping to prevent flooding.
- Inspect bags for holes or rips.
- Remove the sediment behind the barrier when it reaches one-third the height of the barrier.

# STORMDRAIN INLET PROTECTION

# DP-3

## Excavated Drop Inlet Sediment Trap (DI Protection Type 2)

- Used where relatively heavy flows are expected and overflow capacity is needed.
- Size trap to provide a minimum storage capacity of 67 yd<sup>3</sup>/acre of drainage area.
- Remove sediments when the basin volume has been reduced by one half.

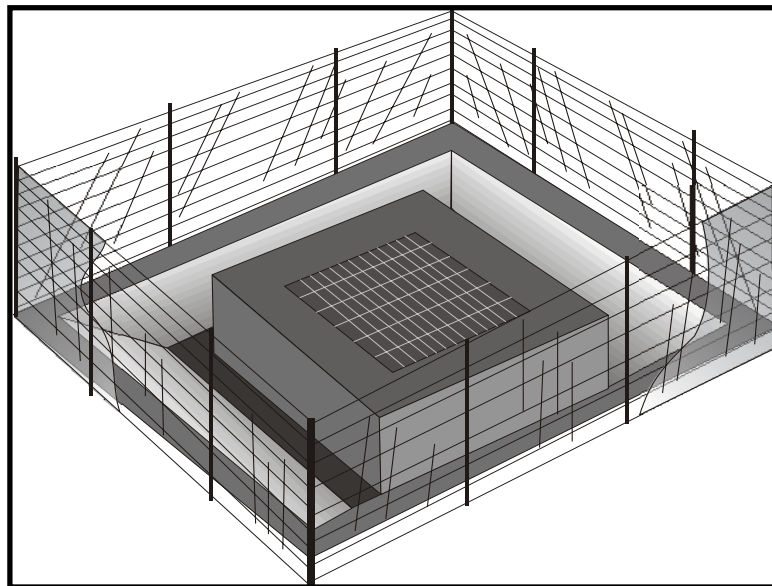

Graphic used with permission of Caltrans

Example of an Excavated Drop Inlet Sediment Trap (DI Protection Type 2)

# STORMDRAIN INLET PROTECTION

# DP-3

## Inspection and Maintenance:

- Inspect before and after rainfall events and weekly during the wet/rainy season.
- Inspect inlet protection devices at least once every 24 hours during extensive rain events.
- Inspect storm drain inlets after severe storms in the rainy season for bypassed material.
- Properly dispose of accumulated sediments.
- From May to October, water should not be allowed to pond behind or within these control measure in excess of 7 days.
- Bring the disturbed area to the grade of the drop inlet and smooth and compact it. Appropriately stabilize all bare areas around the inlet.
- After site is stabilized, remove inlet protection devices or when protection is no longer needed.

# STORMDRAIN INLET PROTECTION

# DP-3

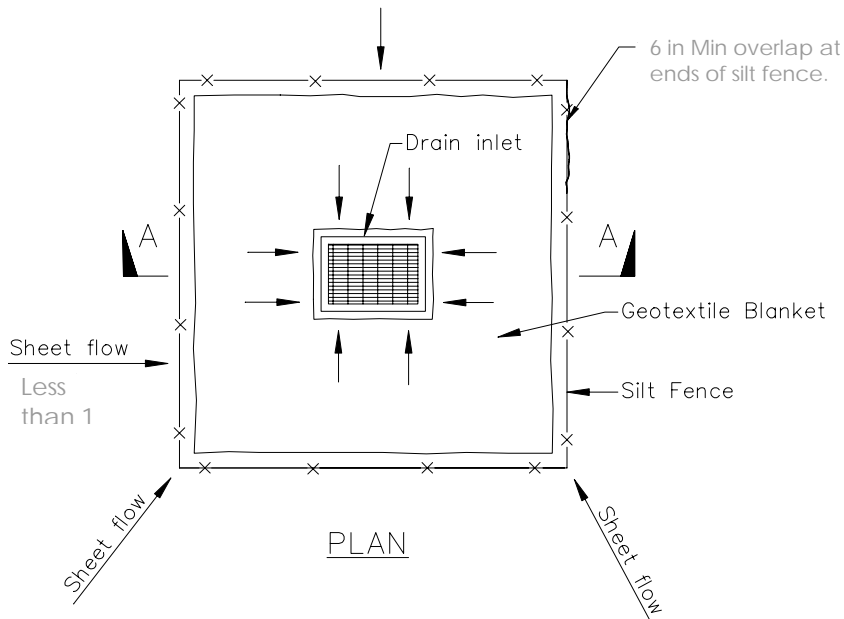
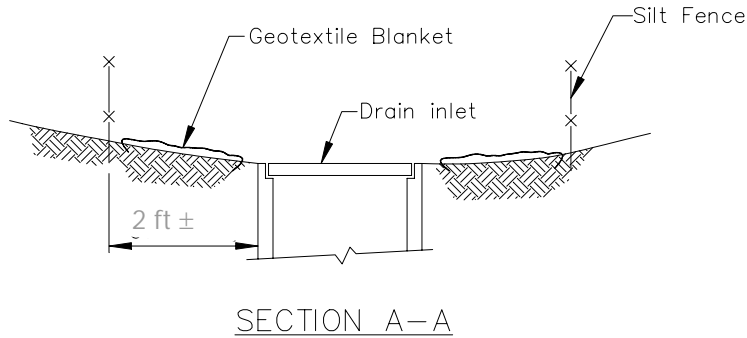

DI PROTECTION TYPE 1  
NOT TO SCALE

NOTES:

1. For use in areas where grading has been completed and final soil stabilization and seeding are pending.
2. Not applicable in paved areas.
3. Not applicable with concentrated flows.

Graphic used with permission of Caltrans.

# STORMDRAIN INLET PROTECTION

# DP-3

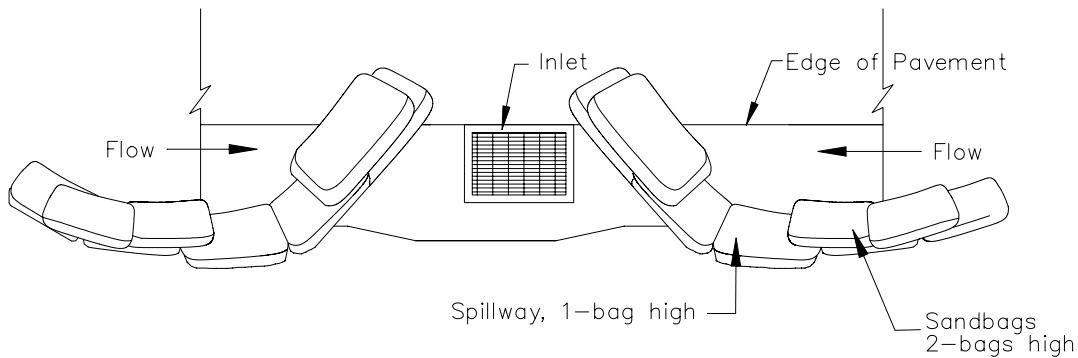

TYPICAL PROTECTION FOR INLET ON SUMP

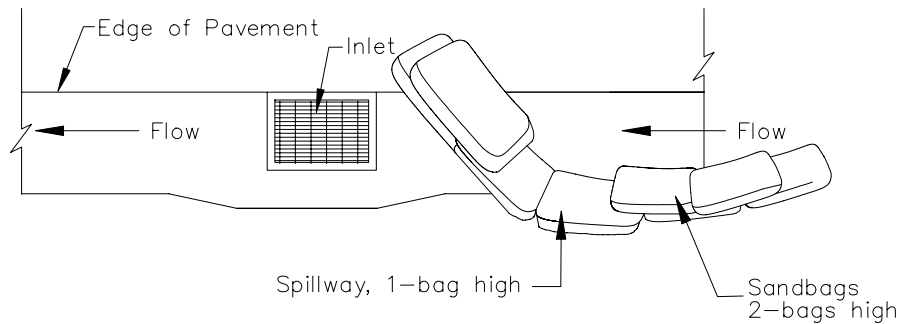

TYPICAL PROTECTION FOR INLET ON GRADE

## NOTES:

1. Intended for short-term use.
2. Use to inhibit non-storm water flow.
3. Allow for proper maintenance and cleanup.
4. Bags must be removed after adjacent operation is completed
5. Not applicable in areas with high silts and clays without filter fabric.

Graphic used with permission of Caltrans.

# STORMDRAIN INLET PROTECTION

# DP-3

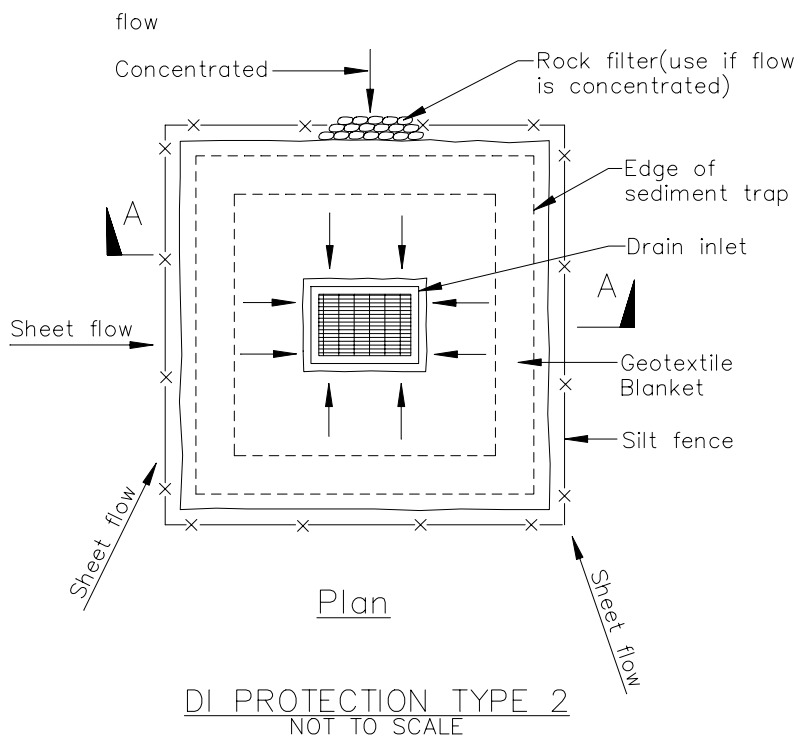
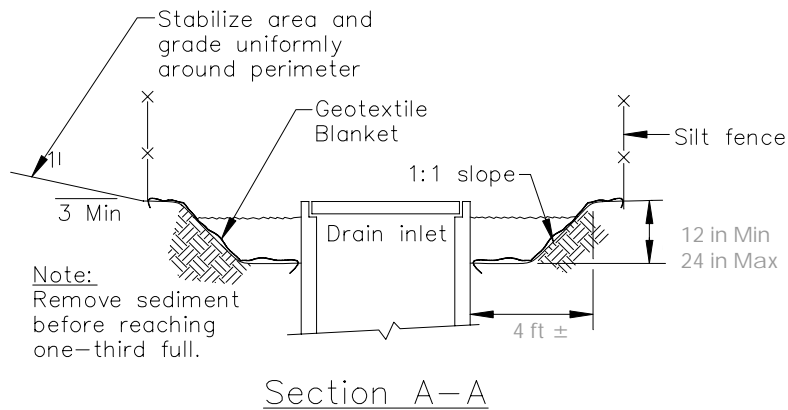

**Notes**

1. For use in cleared and grubbed and in graded areas.
2. Shape basin so that longest inflow area faces longest length of trap.
3. For concentrated flows, shape basin in 2:1 ratio with length oriented towards direction of flow.

Graphic used with permission of Caltrans.

# STOCKPILE MANAGEMENT

# GM-2

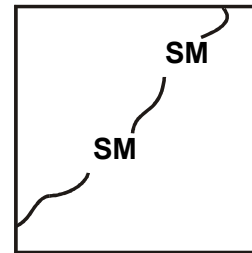
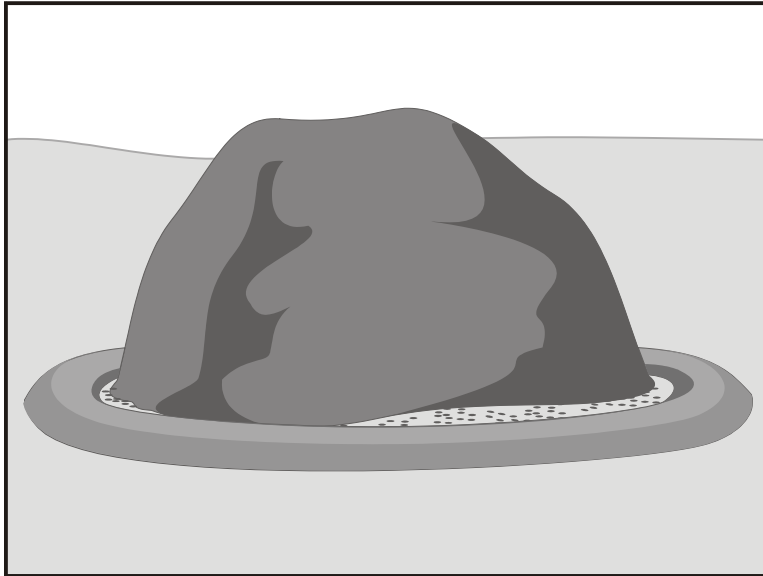

**MAP SYMBOL**

Graphics used with permission of Caltrans

**Purpose:** Proper management of stockpiled materials can reduce or eliminate pollution of stormwater from these sources.

**Application:**

- All locations and projects where materials such as soils, composts, aggregates, and paving materials are stockpiled.

**Limitations:**

- None have been identified.

**Standards and Specifications:**

- Locate stockpiles away from stormwater flows, drainage courses and inlets.
- Use temporary berms, dikes, silt fences, fiber rolls, sandbags or gravel bag barriers to surround and contain stockpiles to prevent transport of materials offsite from stormwater runoff.
- Apply wind erosion and dust control measures on the surface of stockpiles (see EC-5).
- Place bagged materials on pallets and cover. (see GM-10 and GM-11).
- Maintain stockpile management controls year-round.

# STOCKPILE MANAGEMENT

# GM-2

- Install stockpile perimeter controls such as temporary berms, dikes, silt fences, fiber rolls, sandbags or gravel bag barriers as soon as possible after stockpiles are created. These temporary sediment transport barriers can be temporarily removed or moved to one side when materials are removed or added to the stockpile.
- If stockpiles are not to be used within 21 days, temporary covers (e.g. hydromulch, plastic covers, etc.) must be installed as soon as practicable and no later than 14 days after stockpiles are created. Covers shall be placed on stockpiles as soon as practicable where the initiation of temporary covers is precluded by snow or frozen ground conditions.

## **Inspection and Maintenance:**

- Inspect perimeter controls and covers weekly and before and after storm events.
- Inspect temporary covers before, during and after windy weather.
- Replace or repair perimeter controls and covers as needed.

# STREET SWEEPING

# GM-5



MAP SYMBOL

Graphics used with permission of Caltrans

**Purpose:** To remove tracked sediment to prevent it from entering the storm drain system.

**Application:**

- Any location where sediment is tracked from a private construction site onto paved roads.

**Limitations:**

- Wet soil or mud may not allow for effective sweeping.

**Standards and Specifications:**

- Follow the policies stated in Standard No. 1 of the Construction Permit Submittal Checklist (Appendix D).
- Follow all applicable District Health dust control standards.
- Consider reusing the sediments on the project if trash and debris are not mixed in with the soil.

**Inspection and Maintenance:**

- Daily inspection of potential sediment tracking locations.
- Daily inspection of egress/ingress access points.
- Daily sweeping and vacuuming of visible sediment tracking.
- Do not sweep up any potentially hazardous materials or objects.
- Adjust brooms on sweeper frequently to maximize efficiency.
- Proper disposal of sweeper waste is necessary.

# SPILL PREVENTION AND CONTROL

# GM-6

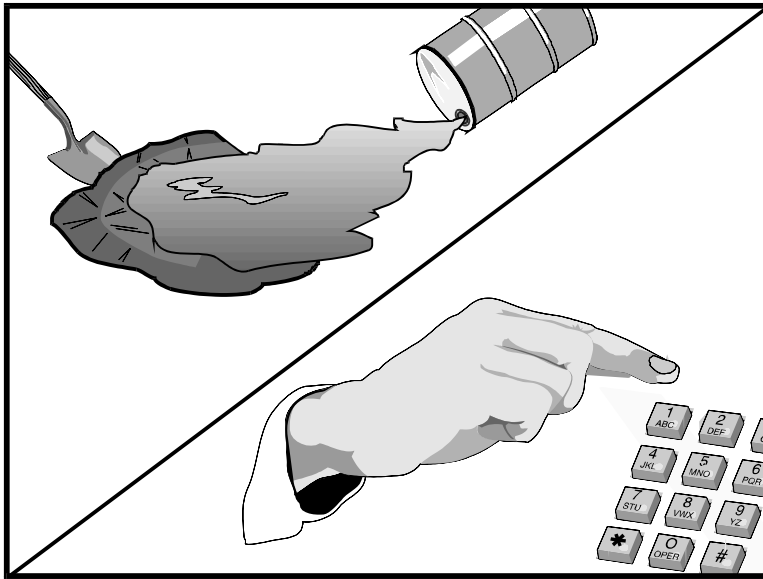

Graphics used with permission of Caltrans

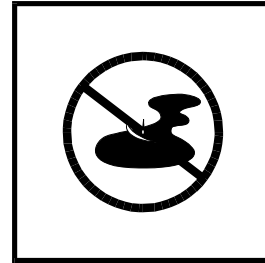

MAP SYMBOL

**Purpose:** Discharges of non-hazardous and hazardous materials to the storm drain system can be minimized or eliminated by preventing and controlling spills through defined procedures and practices.

**Application:**

- Applies to all construction sites.
- Implemented any time chemicals are used (including fuel areas).
- Chemicals include (but are not limited to): soil stabilizers, dust palliatives, herbicides, growth inhibitors, fertilizers, deicing chemicals, fuels, paints, solvents, cement, lubricants, and other petroleum distillates.

**Limitations:**

- The described practices are general and therefore should be adjusted by the contractor for the specific materials used or stored on-site.
- Applies only to spills caused by the contractor.

**Standards and Specifications:**

- Do not bury or wash spills with water.
- Attempt to cover spills during rainfall events as long as clean up efforts are not compromised.
- Do not allow water used for clean up purposes to enter the storm drain system.

# SPILL PREVENTION AND CONTROL

# GM-6

- Keep waste storage areas clean, well organized, and well equipped.
- Information on proper storage, clean up and spill reports should be posted at a visible and accessible location at all times.
- Educate employees and subcontractors about what a “significant” and “insignificant” spill is for each chemical used on-site and train in spill prevention and cleanup.
- Hold regular meetings to discuss and reinforce disposal procedures (incorporate into regular safety meetings).
- Locate chemical storage and handling areas away from storm drains, waterways, or reservoirs.
- Do not store chemicals in areas where they may be susceptible to rain.
- Provide a secondary containment structure in case of leaks or spills.
- Always use a secondary containment, such as a drain pan or drop cloth, to catch spills or leaks when removing or changing fluids.
- Place drip pans or absorbent material under paving equipment when not in use.
- Promptly transfer used fluids to the proper waste or recycling drums. Do not leave full drip pans or other open containers lying around.
- Oil filters disposed of in trashcans or dumpsters can leak oil and pollute stormwater. Place the oil filter in a funnel over a waste oil-recycling drum to drain excess oil before disposal.
- Store cracked batteries in a non-leaking secondary container.
- If vehicles will be fueled on site:
  - Discourage “topping off”.
  - Use designated areas located away from waterways and drainages.
  - Use a secondary containment to catch drips or spills.
- Place a stockpile of spill cleanup materials where it will be readily accessible.
- Clean up spills immediately and dispose of contaminated soils and clean up materials properly.
  - Sweep up dry spills. Do not wash or hose down the area.
  - Wet spills on impermeable surfaces should be absorbed.
  - Wet spills on soils require digging up and disposing of the contaminated soil.

# SPILL PREVENTION AND CONTROL

# GM-6

- A secondary containment with enough capacity to contain a spill is required for fueling areas.
- Report significant spills to local and state agencies, such as the Fire Department or NDEP, who may assist in the cleanup.
- Federal regulations require that any significant oil spill into a water body or onto an adjoining shoreline be reported to the National Response Center (NRC) at 800-424-8802 (24 hours).
- Only a reputable, licensed company should be used to clean up large spills and dispose of contaminated materials.

## **Inspection and Maintenance:**

- On a weekly basis, ensure that an adequate supply of spill control cleanup materials are located close to storage, fueling, and unloading areas.
- Inspect containment structures in fueling and storage areas.
- Spill prevention plans should be updated when the types of chemicals stored on site changes.
- Regularly inspect on-site vehicles and equipment for leaks, and repair them immediately.

# HANDLING AND DISPOSAL OF CONCRETE AND CEMENT

## GM-9

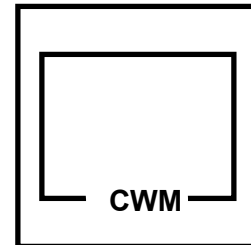
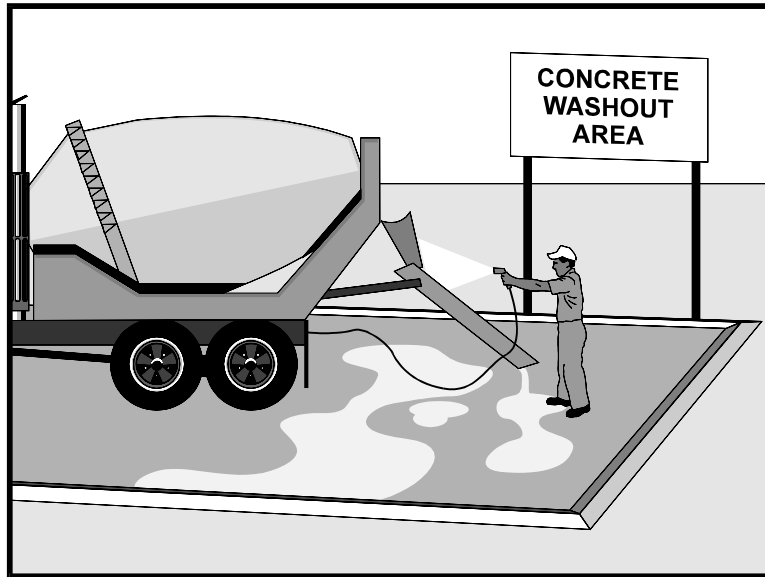

MAP SYMBOL

Graphics used with permission of Caltrans

**Purpose:** To prevent pollution from concrete and mortars by providing a designated washout area for trucks, tools, and mortar mixers.

**Application:**

- For the storing of wet and dry concrete and cement mortar materials.
- For the on-site preparation of concrete and cement mortars.
- Washing out of concrete equipment on-site.

**Limitations:**

- Site may constrain location of an appropriate wash out area.

**Standards and Specifications:**

- Educate all employees and subcontractors on concrete waste management.
- Collect and dispose of properly all PCC and AC waste so that it does not enter the storm drain system.
- Post a sign next to the temporary concrete washout areas.
- Concrete washout facilities can be designed above or below grade. Below grade facilities are preferred.
- Collect and dispose of properly all slurry residues.

# HANDLING AND DISPOSAL OF CONCRETE AND CEMENT

## GM-9

- Place a berm around concrete washout facilities to prevent runoff from entering below grade pits.
- The capacity of concrete washout facilities should be determined based on the estimated amount of concrete washout waste generated at site. The volume must also be designed to contain any runoff that drains to the facility and the rain falling directly into the facility during the 2-yr, 24-hr storm event.
- Concrete washout facilities should be used only to temporarily contain washwater from the cleaning of concrete-coated equipment and washout from concrete trucks.
- Concrete washout facilities should not be for disposal of excess concrete and cement and trucks should not be allowed to back turn and dispose of residual loads.
- Concrete washout facilities may need to be lined if the area is located near a stream or waterbody or in an area of shallow groundwater.
- Locate concrete washout areas a minimum of 50 feet from, waterways and the storm drain system.
- Mix only an appropriate amount of fresh concrete or cement mortar.
- Store materials away from waterways or storm drains.
- Perform wash out activities in the designated areas.
- 
- Recycle washout water by pumping it back into the mixers for reuse. However, if this is not feasible then allow the wastewater to percolate into the ground and/or evaporate. Collect and dispose of the remaining concrete.

### **Inspection and Maintenance:**

- Dispose of wastes at least once per week.
- When the washout is 75 percent full, it must be cleaned or a new washout must be constructed.

# MATERIAL DELIVERY, HANDLING, STORAGE AND USE

## GM-10

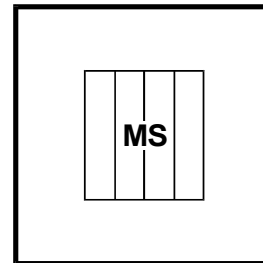
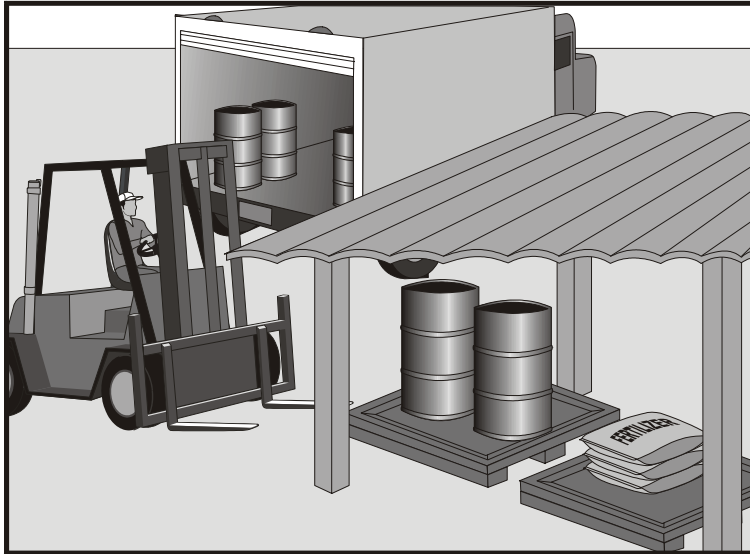

MAP SYMBOL

Graphics used with permission of Caltrans

**Purpose:** To minimize or eliminate the discharge of hazardous or non-hazardous materials to storm drains, watercourses, or drainage channels.

**Application:**

- All construction sites that have delivery and storage of:
  - Fuel, oil, grease
  - Herbicides, pesticides, fertilizers
  - Asphalt, concrete and their components
  - Acids, curing and form compounds
  - Other hazardous materials

**Limitations:**

- All temporary storage buildings must meet building codes.
- Storage must meet fire codes.
- All secondary containment structures and materials should be removed from the site upon completion of the project and disposed of according to regulations.

# MATERIAL DELIVERY, HANDLING, STORAGE AND USE

## GM-10

### Standards and Specifications:

- Designate a storage area that is not near a storm drain or watercourse.
- All contractors and subcontractors must train employees in proper materials handling, storage, application and delivery procedures.
- Follow manufacturers' instructions on application, storage and disposal of materials.
- Store onsite only the amount of material necessary for the job.
- Use non-hazardous and environmentally friendly products.
- Provide indoor storage or cover stockpiled materials and wastes with a tarp.
- Provide covered storage for secondary containment of hazardous materials.
- Use secondary storage to prevent soil contamination.
- Monitor employees and subcontractors to ensure that proper practices are being implemented.
- Keep all material in original containers.
- Label all stored materials according to state, local and federal regulations.
- Do not store incompatible materials together.
- Keep adequate supply of cleanup materials on site at all times.
- Report all spills.
- Do not apply hazardous chemicals during wet or windy conditions.

### Inspection and Maintenance:

- Inspect storage areas weekly to ensure neatness.
- Post proper storage instructions and Material Safety Data Sheets (MSDS) for all currently stored materials.
- Repair and replace damaged secondary containment facilities.
- Remove all empty containers and packaging from site.
- Store materials with adequate clearances for access and emergency response.

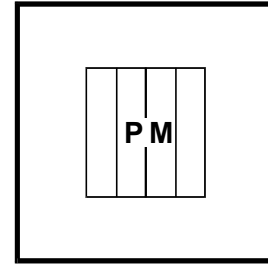
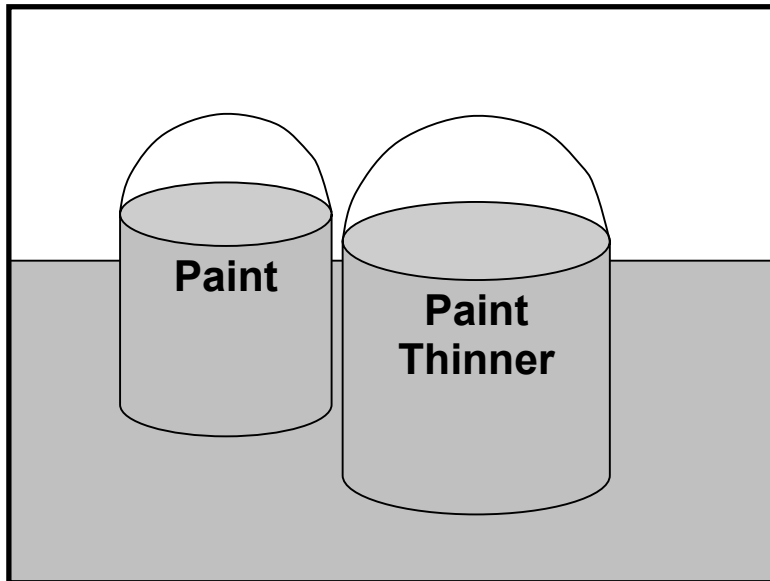

**MAP SYMBOL**

Graphics produced by Kennedy/Jenks Consultants

**Purpose:** To minimize or eliminate the discharge of hazardous or non-hazardous paint wastes, adhesives, solvents and cleaning products to storm drains, watercourses and drainage channels.

**Application:**

- Hazardous residues from paints, thinners, solvents, cleaning agents.
- Non-hazardous materials such as paint cans, brushes, rags, drop cloths.
- Paint removal wastes such as chemical stripping residues, paint chips, sand blasting material and wash water.

**Limitations:**

- Hazardous wastes must be either recycled or disposed of by a licensed hazardous waste hauler.
- Storage must meet Fire Codes.

**Standards and Specifications:**

- Designate specific storage and cleaning areas.
- Use non-hazardous and environmentally friendly products when possible.
- Do not clean brushes or rinse containers near storm drains, watercourses or drainage channels.
- Keep all paints, liquids and wastes away from gutters, storm drains, watercourses and drainage channels.

- Sweep up non-hazardous sand blasting residue and paint chips. Dispose of these wastes in the garbage.
- Dispose of old brushes, rollers, and dried latex paint in the garbage.
- Pre-1970 paint should be tested for lead. Follow regulations if lead is present.
- Dispose of non-recyclable oil based or other products as hazardous waste.
- Residues, paint chips, or dust which contains lead or tributyl tin should be disposed of as hazardous waste.
- Recycle empty, dry paint cans if possible.
- Water based paints should be painted out of brushes as much as possible before rinsing them in an area that drains to the sanitary sewer.
- When water blasting and stripping building exteriors, cover or berm storm drain inlets to prevent waste from entering gutters, storm drains, watercourses and drainage channels. If appropriate, dispose of wastewater in the sanitary sewer.

## **Inspection and Maintenance:**

- Monitor employees and subcontractors to ensure that proper practices are being implemented.

# PAVEMENT CONSTRUCTION MANAGEMENT GM-12

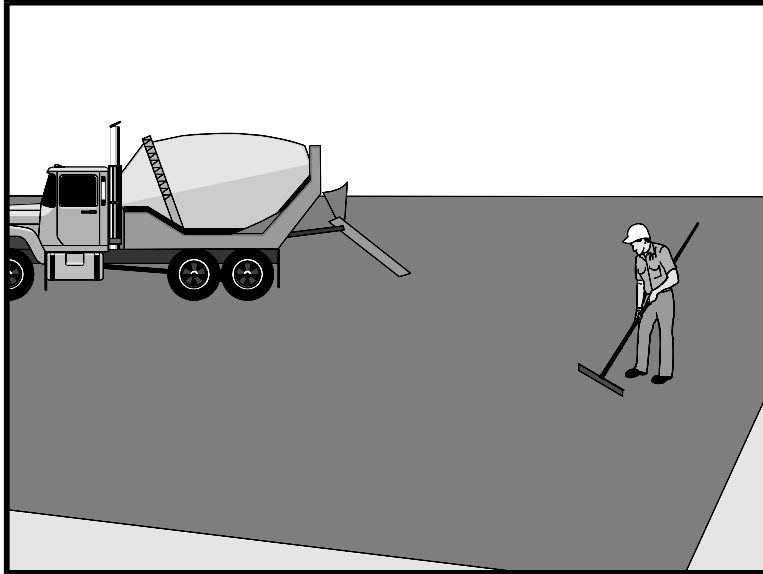

**MAP SYMBOL**

Graphics used with permission of Caltrans

**Purpose:** To minimize or eliminate the discharge of on-site paving, surfacing, asphalt or concrete materials to storm drains, gutters or water courses.

**Application:**

- Application of concrete, asphalt, seal coats, tack coats, slurries etc.
- Application of thermoplastic striping and pavement markers.
- Pavement recycling operations.
- Storage of paving equipment.
- Saw cutting and saw cutting residue.
- Cleaning of asphalt.
- Removal of existing concrete or asphalt.

**Limitations:**

- Do not apply materials in rainy or inclement weather that would allow materials to come into contact with stormwater.

# PAVEMENT CONSTRUCTION MANAGEMENT GM-12

## Standards and Specifications:

- Protect drainage ways with earth dikes, filter fabric, or sand bags to divert or capture runoff from seal coats, tack coats, slurry or fog seals. Gather and properly dispose of trapped material.
- Substances used to coat asphalt trucks and equipment shall not contain detergent and shall be non-foaming and nontoxic.
- Minimize the washing of sands, gravels and asphalt from paving, sealing, grinding or coating operations into storm drains, watercourses and drainage channels.
- Dispose of spilled oil and asphalt off site according to all state, local and federal regulations.
- Do not clean paving equipment on site.
- Use as little water as possible during saw cutting operations.
- Do not allow saw cut slurry to enter storm drains, watercourses or drainage channels. Gather and remove wastes from the site at the end of the day.
- Remove asphalt from digouts, grinding and leveling operations from the site and dispose of according to local, state and federal regulations.
- Saw cutting slurry should be collected as generated.

## Inspection and Maintenance:

- Monitor employees and subcontractors to ensure that proper practices are being implemented.
- Park paving equipment over drip pans or absorbent material. Dispose of waste properly.
- Repair leaking machinery.
- Inspect inlet protection devices both before and after storm events. Devices should be checked daily during extended storm events.
- Stormwater should not back up into active traffic areas.

# SANITARY/SEPTIC WASTE MANAGEMENT

# GM-14

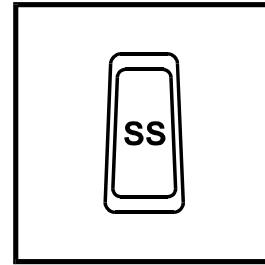
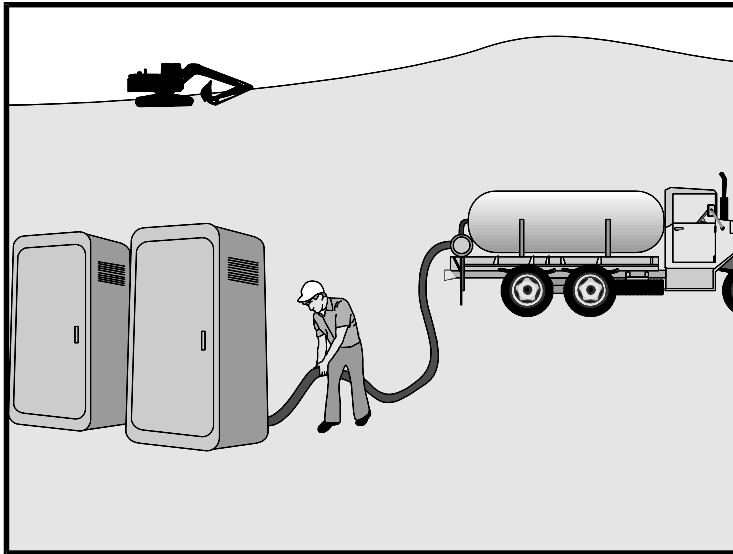

MAP SYMBOL

Graphics used with permission of Caltrans

**Purpose:** To minimize or eliminate the discharge of sanitary wastes from construction sites to storm drains, gutters, watercourses and drainage channels.

**Application:**

- Applies to construction sites that have portable or temporary sanitary waste systems.

**Limitations:**

- To dispose of wastes to the sanitary sewer, the leasing company must be permitted.
- On-site disposal systems must comply with all local, and state regulations.
- Temporary connections to the sanitary sewer should meet codes and regulations.

**Standards and Specifications:**

- Locate toilets and disposal systems where accidental discharge cannot flow to storm drains, gutters, watercourses and drainage channels.
- Anchor portable toilets so they do not overturn during high winds.
- All sanitary wastes shall eventually be discharged to a sanitary sewer.
- Educate workers on the potential harm to the environment from sanitary wastes.

# SANITARY/SEPTIC WASTE MANAGEMENT **GM-14**

- Employ licensed sanitary services to ensure facilities are in working order at all times.

## **Inspection and Maintenance:**

- Monitor employees and subcontractors to ensure that proper practices are being implemented.
- Sanitary storage and disposal should be inspected at least once per week. Units should be properly maintained, repaired, or replaced.

**TRUCKEE MEADOWS REGIONAL STORMWATER QUALITY MANAGEMENT PROGRAM**

**CONSTRUCTION SITE INSPECTION CHECKLIST**

Page \_\_\_ of \_\_\_

The contractor or other responsible party shall inspect the site at a minimum weekly, prior to forecasted rain events and within 24 hours of any rain event that creates runoff at the site. Inspection checklists shall be maintained onsite for review by State and local government inspectors.

**Project Name and File Number:** \_\_\_\_\_  
**Project Location:** \_\_\_\_\_

**Date:** \_\_\_\_\_ **Inspected by:** \_\_\_\_\_  
**(Name and Company)**

**Type of Inspection:** Routine  Pre-Storm  Post-Storm

- | Yes                      | No                       | N/A                      |   |
|--------------------------|--------------------------|--------------------------|---|
| <input type="checkbox"/> | <input type="checkbox"/> | <input type="checkbox"/> | 1. Has there been rain since the last inspection?   |
| <input type="checkbox"/> | <input type="checkbox"/> | <input type="checkbox"/> | 2. Are roadways, storm drains, watercourses or swales or channels leading offsite free of sedimentation, litter, wastes and hazardous materials?                              |
| <input type="checkbox"/> | <input type="checkbox"/> | <input type="checkbox"/> | 3. Have all denuded areas requiring temporary or permanent stabilization been stabilized?   |
| <input type="checkbox"/> | <input type="checkbox"/> | <input type="checkbox"/> | 4. Does the stabilization BMP cover the area intended?  |
| <input type="checkbox"/> | <input type="checkbox"/> | <input type="checkbox"/> | 5. Are all sediment barriers (e.g. sandbags, silt fences) in place according to the grading plans or subsequent plan update and are they installed and functioning correctly? |
| <input type="checkbox"/> | <input type="checkbox"/> | <input type="checkbox"/> | 6. If sediment basins are used, is there 50% or more capacity remaining?  |
| <input type="checkbox"/> | <input type="checkbox"/> | <input type="checkbox"/> | 7. Are water diversion structures functioning adequately with appropriate outlet protection and no evidence of erosion from their discharge?                                  |
| <input type="checkbox"/> | <input type="checkbox"/> | <input type="checkbox"/> | 8. Are onsite channels stabilized?  |
| <input type="checkbox"/> | <input type="checkbox"/> | <input type="checkbox"/> | 9. Do all onsite and adjacent storm drain inlets have inlet protection?   |
| <input type="checkbox"/> | <input type="checkbox"/> | <input type="checkbox"/> | 10. Are all watercourse and vegetation protection measures in place and adequately maintained?  |
| <input type="checkbox"/> | <input type="checkbox"/> | <input type="checkbox"/> | 11. Are all materials and equipment not in use located in designated storage and maintenance areas?   |
| <input type="checkbox"/> | <input type="checkbox"/> | <input type="checkbox"/> | 12. Are all material and equipment storage and maintenance areas reasonably clean and free of spills, leaks or other sources of potentially polluting materials?              |



## POTENTIAL POLLUTANT SOURCES

Category	Possible Products	Potential Pollutants
Adhesives	<ul style="list-style-type: none"> <li>▶ Adhesives, Glues</li> <li>▶ Resins, Epoxy Synthetics</li> <li>▶ Caulks, Sealers, Putty, Sealing Agents</li> <li>▶ Coal Tars (Naphtha, Pitch)</li> </ul>	<ul style="list-style-type: none"> <li>▶ Phenolic, Formaldehyde</li> <li>▶ Phenolic, Formaldehyde</li> <li>▶ Asbestos, Phenolic</li> <li>▶ Formaldehyde, Benzene, Phenols, Naphthalene</li> </ul>
Cleaners	<ul style="list-style-type: none"> <li>▶ Polishes (Metal, Ceramic, Tile)</li> <li>▶ Etching Agents</li> <li>▶ Cleaners, Ammonia, Lye, Caustic Sodas</li> <li>▶ Bleaching Agents</li> <li>▶ Chromate Salts</li> </ul>	<ul style="list-style-type: none"> <li>▶ Metals</li> <li>▶ Metals</li> <li>▶ Acidity/Alkalinity</li> <li>▶ Acidity/Alkalinity</li> <li>▶ Chromium</li> </ul>
Plumbing	<ul style="list-style-type: none"> <li>▶ Solder (Lead, Tin), Flux (Zinc Chloride)</li> <li>▶ Pipe Fitting (Cut Shavings)</li> <li>▶ Galvanized metals (Nails, Fences)</li> <li>▶ Electric Wiring</li> </ul>	<ul style="list-style-type: none"> <li>▶ Lead, Copper, Zinc, Tin</li> <li>▶ Copper</li> <li>▶ Zinc</li> <li>▶ Copper, Lead</li> </ul>
Painting	<ul style="list-style-type: none"> <li>▶ Paint Thinner, Acetone, MEK, Stripper</li> <li>▶ Paints, Lacquers, Varnish, Enamels</li> <li>▶ Turpentine, Gum spirit, Solvents</li> <li>▶ Sanding, Stripping</li> <li>▶ Paints (Pigments), Dyes</li> </ul>	<ul style="list-style-type: none"> <li>▶ VOCs</li> <li>▶ Metals, Phenolic, Mineral Sprit</li> <li>▶ VOCs</li> <li>▶ Metals</li> <li>▶ Metals</li> </ul>
Woods	<ul style="list-style-type: none"> <li>▶ Sawdust</li> <li>▶ Particle Board Dusts (Formaldehyde)</li> <li>▶ Treated Woods</li> </ul>	<ul style="list-style-type: none"> <li>▶ Solid Wastes</li> <li>▶ Formaldehyde</li> <li>▶ Copper, Creosote</li> </ul>
Masonry and Concrete	<ul style="list-style-type: none"> <li>▶ Dusts (Brick, Cement)</li> <li>▶ Colored Chalks (Pigments)</li> <li>▶ Glazing Compounds</li> <li>▶ Cleaning Surfaces</li> </ul>	<ul style="list-style-type: none"> <li>▶ Acidity, Sediments</li> <li>▶ Metals</li> <li>▶ Asbestos</li> <li>▶ Acidity</li> </ul>
Floors and Walls	<ul style="list-style-type: none"> <li>▶ Flashing</li> <li>▶ Drywall</li> <li>▶ Tile Cutting (Ceramic Dusts)</li> <li>▶ Adhesives<sup>2</sup></li> </ul>	<ul style="list-style-type: none"> <li>▶ Copper, Aluminum</li> <li>▶ Dusts</li> <li>▶ Minerals</li> </ul>
Remodeling and Demolition	<ul style="list-style-type: none"> <li>▶ Insulation</li> <li>▶ Venting Systems</li> <li>▶ Brick, Cement, Saw, Drywall</li> </ul>	<ul style="list-style-type: none"> <li>▶ Asbestos</li> <li>▶ Aluminum, Zinc</li> <li>▶ Dusts</li> </ul>
Air Conditioning and Heating	<ul style="list-style-type: none"> <li>▶ Insulating</li> <li>▶ Coolant Reservoirs</li> <li>▶ Adhesives</li> </ul>	<ul style="list-style-type: none"> <li>▶ Asbestos</li> <li>▶ Freon</li> </ul>

<sup>2</sup> See above categories.

Yard O&M	<ul style="list-style-type: none"> <li>▶ Vehicle and Machinery Maintenance</li> <li>▶ Gasoline, Oils, Additives</li> <li>▶ Marking Paints (Sprays)</li> <li>▶ Grading, Earth Moving</li> <li>▶ Portable Toilets</li> <li>▶ Fire Hazard control (Herbicides)</li> <li>▶ Health and Safety</li> <li>▶ Wash Waters</li> </ul>	<ul style="list-style-type: none"> <li>▶ Oils and Grease, Coolants</li> <li>▶ Benzene and Derivatives, Oils and Grease</li> <li>▶ Vinyl Chloride, Metals</li> <li>▶ Erosion (Sediments)</li> <li>▶ BOD, Disinfectants (Spills)</li> <li>▶ Sodium Arsenite, Di-nitro</li> <li>▶ Compounds, BOD, Rodenticides, Insecticides, Herbicides, Concrete, Greases</li> </ul>
Landscaping and Earth Moving	<ul style="list-style-type: none"> <li>▶ Planting, Plant Maintenance</li> <li>▶ Excavation, Tilling</li> <li>▶ Masonry and Concrete</li> <li>▶ Trees and shrubs</li> <li>▶ Exposing Natural Lime or Mineral Deposits</li> <li>▶ Soils Additives</li> <li>▶ Re-vegetation of Graded Areas</li> </ul>	<ul style="list-style-type: none"> <li>▶ Pesticides, Herbicides, Nutrients</li> <li>▶ Erosion (Sediments)</li>   <li>▶ Solid Wastes</li> <li>▶ Acidity/Alkalinity, Metals</li>   <li>▶ Aluminum Sulfate, Sulfur</li> <li>▶ Fertilizer</li> </ul>
Materials Storage	<ul style="list-style-type: none"> <li>▶ Waste Storage (Used Oils, Solvents, Etc.)</li> <li>▶ Hazardous Waste Containment</li> <li>▶ Raw Material Piles</li> </ul>	<ul style="list-style-type: none"> <li>▶ Spills, Leaks, Polluted Discharge</li> <li>▶ spills, Leaks, Polluted Discharge</li> <li>▶ Dusts, Sediments, Polluted Discharge</li> </ul>

VOC: Volatile Organic Compound

BOD: Biological Oxygen Demand