

BENEFICIARY ELIGIBLE MITIGATION ACTION CERTIFICATION

Beneficiary _____

Lead Agency Authorized to Act on Behalf of the Beneficiary _____
(Any authorized person with delegation of such authority to direct the Trustee delivered to the Trustee pursuant to a Delegation of Authority and Certificate of Incumbency)

Action Title:	
Beneficiary's Project ID:	
Funding Request No.	<i>(sequential)</i>
Request Type: (select one or more)	<input type="checkbox"/> Reimbursement <input type="checkbox"/> Advance <input type="checkbox"/> Other (specify): _____
Payment to be made to: (select one or more)	<input type="checkbox"/> Beneficiary <input type="checkbox"/> Other (specify): _____
Funding Request & Direction (Attachment A)	<input type="checkbox"/> Attached to this Certification <input type="checkbox"/> To be Provided Separately

SUMMARY

Eligible Mitigation Action <input type="checkbox"/> Appendix D-2 item (specify): _____ Action Type <input type="checkbox"/> Item 10 - DERA Option (5.2.12) (specify and attach DERA Proposal): _____			
Detailed Description of Mitigation Action Item Including Community and Air Quality Benefits (5.2.2):			
Estimate of Anticipated NOx Reductions (5.2.3):			
Identification of Governmental Entity Responsible for Reviewing and Auditing Expenditures of Eligible Mitigation Action Funds to Ensure Compliance with Applicable Law (5.2.7.1):			
Describe how the Beneficiary will make documentation publicly available (5.2.7.2).			
Describe any cost share requirement to be placed on each NOx source proposed to be mitigated (5.2.8).			
Total project budget:	Project costs paid by the Trust:	Administrative Costs:	Cost share requirement:
\$ 463,316.20	\$ 265,000.00	\$ 26,500.00	\$ 171,816.20
Describe how the Beneficiary complied with subparagraph 4.2.8, related to notice to U.S. Government Agencies (5.2.9).			
NDEP sent emails to the representatives from the U.S. Department of the Interior and the U.S. Department of Agriculture listed in subparagraph 4.2.8 of the State Trust Agreement on February 23, 2018.			

If applicable, describe how the mitigation action will mitigate the impacts of NOx emissions on communities that have historically borne a disproportionate share of the adverse impacts of such emissions (5.2.10).

ATTACHMENTS
(CHECK BOX IF ATTACHED)

- Attachment A Funding Request and Direction.
- Attachment B Eligible Mitigation Action Management Plan Including Detailed Budget and Implementation and Expenditures Timeline (5.2.4).
- Attachment C Detailed Plan for Reporting on Eligible Mitigation Action Implementation (5.2.11).
- Attachment D Detailed cost estimates from selected or potential vendors for each proposed expenditure exceeding \$25,000 (5.2.6). [Attach only if project involves vendor expenditures exceeding \$25,000.]
- Attachment E DERA Option (5.2.12). [Attach only if using DERA option.]
- Attachment F Attachment specifying amount of requested funding to be debited against each beneficiary's allocation (5.2.13). [Attach only if this is a joint application involving multiple beneficiaries.]

CERTIFICATIONS

By submitting this application, the Lead Agency makes the following certifications:

1. This application is submitted on behalf of Beneficiary _____, and the person executing this certification has authority to make this certification on behalf of the Lead Agency and Beneficiary, pursuant to the Certification for Beneficiary Status filed with the Court.
2. Beneficiary requests and directs that the Trustee make the payments described in this application and Attachment A to this Form.
3. This application contains all information and certifications required by Paragraph 5.2 of the Trust Agreement, and the Trustee may rely on this application, Attachment A, and related certifications in making disbursements of trust funds for the aforementioned Project ID.
4. Any vendors were or will be selected in accordance with a jurisdiction's public contracting law as applicable. (5.2.5)
5. Beneficiary will maintain and make publicly available all documentation submitted in

support of this funding request and all records supporting all expenditures of eligible mitigation action funds subject to applicable laws governing the publication of confidential business information and personally identifiable information. (5.2.7.2)

DATED: 7/8/22

Danilo Dragoni, PhD

[NAME]



[SIGNATURE]

Chief, Bureau of Air Quality Planning

[TITLE]

Nevada Division of Environmental Protection

[LEAD AGENCY]

for

Nevada

[BENEFICIARY]

**DETAILED DESCRIPTION OF MITIGATION ACTION ITEM INCLUDING
COMMUNITY AND AIR QUALITY BENEFITS (5.2.2)**

The Nevada Division of Environmental Protection (NDEP) is submitting this Eligible Mitigation Action Category 1 - Class 8 Local Freight Trucks and Port Drayage Trucks (Eligible Large Trucks) semi-truck replacement project to support the early retirement and replacement of one diesel-powered semi-truck, owned and operated by Grand Laundry Inc (a subsidiary of MGM Grand Hotel, LLC), with one brand-new electric-powered semi-truck, located in Las Vegas, Nevada. Upon completion of this project, the permanent scrapping of one non-government owned semi-truck will provide a direct benefit to air quality.

The details regarding the individual unit being replaced through this project, as well as the replacement unit, is included on pages 5 and 6 of this submission. The NDEP will work with MGM Grand on the scrapping of the program-eligible semi-truck and will coordinate with their staff for routine updates and possible site visits to ensure a timely and efficient completion of this project. The NDEP will not seek to have MGM Grand Hotel, LLC reimbursed for this project until they have provided sufficient scrapping evidence to the NDEP.

The total expected lifetime emissions reductions are provided in the table below. They were calculated using the Microsoft Excel based version of the Alternative Fuel Life-Cycle Environmental and Economic Transportation (AFLEET) Tool.¹

Pollutant	Emissions Reductions (tons)
NO _x	0.564
PM _{2.5}	0.008
PM ₁₀	0.049
CO	0.461
VOC	0.039
SO _x	0.008
GHG	1,418.72

¹ The AFLEET Tool is available online at <https://greet.es.anl.gov/afleet>.

Existing Vehicle/Engine Information	
Fleet Information	Unit 1
What is the vehicle's intended use?	Laundry delivery from plant to resort
Vehicle License Plate Number	93102P
Vehicle GVWR	41,000
Vehicle Make	Kenworth
Vehicle Model	T300 Tractor
Vehicle Model Year	2002
Vehicle Identification Number	2XKMAD7X52M886583
Engine Make	Caterpillar
Engine Model	Caterpillar 3126 250HP
Engine Model Year	2001
Engine Serial Number	CKM22238
Fuel Type	ULSD
Annual Fuel Used	9,216
Annual Vehicle Mileage	36,865
Total Vehicle Mileage	413,696
Total Engine Mileage	N/A
Remaining Vehicle Life	1
Normal Attrition Year	2023
Is this vehicle registered with a Nevada intrastate license?	Yes
Replacement/Repower Vehicle/Engine Information	
Fleet Information	Unit 1
Vehicle GVWR	32,350
Vehicle Make	Volvo
Vehicle Model	NRE42T300
Vehicle Model Year	2023
Engine Make	Volvo
Engine Model	340 KW (455 HP) ELECTRIC MOTOR
Engine Model Year	2023
Fuel Type	BATTERY ELECTRIC
Unit Replacement/Repower Cost	\$436,816.20

Unit	DEQ or AFLEET	Unit Cost	Amount Requested	EMISSIONS REDUCTIONS (TONS)								
				NOx	PM2.5	PM10	CO	HC	CO2	VOC	SOx	GHGs
Unit 1	AFLEET	\$ 436,816.20	\$ 265,000.00	0.564	0.008	0.049	0.461	-	-	0.039	0.008	1,418.72
TOTAL		\$ 436,816.20	\$ 265,000.00	0.564	0.008	0.049	0.461	-	-	0.039	0.008	1,418.72

ATTACHMENT FOR 5.2.7.2

Describe how the Beneficiary will make documentation publicly available

Subparagraph 5.2.7.2 of the Environmental Mitigation Trust Agreement for State Beneficiaries requires that Beneficiaries include in their funding requests:

A commitment by the Beneficiary to maintain and make publicly available all documentation submitted in support of the funding request and all records supporting all expenditures of Eligible Mitigation Action funds, subject to applicable laws governing the publication of confidential business information and personally identifiable information, together with an explanation of the procedures by which the Beneficiary shall make such documentation publicly available;

The Nevada Division of Environmental Protection (NDEP), the Lead Agency for the State of Nevada, is committed to maintaining and making publicly available all documentation submitted support of the funding requests and all records supporting all expenditures of Eligible Mitigation Action funds, subject to applicable laws governing the publication of confidential business information and personally identifiable information.

The public will be able to view these records on the NDEP's website (<https://ndep.nv.gov>). The NDEP will maintain these records on a Volkswagen (VW) Environmental Mitigation Trust Fund specific webpage that will be designed to support public access and limit burden for the general public. The NDEP's VW specific webpage can currently be found at <https://ndep.nv.gov/air/vw-settlement>.

The NDEP has created an electronic listserv, open to the public, used to communicate news, events, and information related the Environmental Mitigation Trust Fund (Mitigation Fund). The listserv, NevadaVWFund, is advertised through the NDEP website and at public events related to the Mitigation Fund.

Chapters 603A and 239B of the Nevada Revised Statutes (NRS) provide definitions and requirements for handling *personal information*.

NRS Section 603A.040 defines 'Personal Information' as:

1. *"Personal information" means a natural person's first name or first initial and last name in combination with any one or more of the following data elements, when the name and data elements are not encrypted:*
 - (a) *Social security number.*
 - (b) *Driver's license number, driver authorization card number or identification card number.*
 - (c) *Account number, credit card number or debit card number, in combination with any required security code, access code or password that would permit access to the person's financial account.*
 - (d) *A medical identification number or a health insurance identification number.*

- (e) A user name, unique identifier or electronic mail address in combination with a password, access code or security question and answer that would permit access to an online account.*
- 2. The term does not include the last four digits of a social security number, the last four digits of a driver's license number, the last four digits of a driver authorization card number or the last four digits of an identification card number or publicly available information that is lawfully made available to the general public from federal, state or local governmental records.*

NRS Section 239B.030 – *Recorded, filed or otherwise submitted documents* - states that:

- 1. Except as otherwise provided in subsections 2 and 6, a person shall not include and a governmental agency shall not require a person to include any personal information about a person on any document that is recorded, filed or otherwise submitted to the governmental agency on or after January 1, 2007.*
- 2. If personal information about a person is required to be included in a document that is recorded, filed or otherwise submitted to a governmental agency on or after January 1, 2007, pursuant to a specific state or federal law, for the administration of a public program or for an application for a federal or state grant, a governmental agency shall ensure that the personal information is maintained in a confidential manner and may only disclose the personal information as required:*
- (a) To carry out a specific state or federal law; or*
- (b) For the administration of a public program or an application for a federal or state grant.*
- Any action taken by a governmental agency pursuant to this subsection must not be construed as affecting the legality of the document.*
- 3. A governmental agency shall take necessary measures to ensure that notice of the provisions of this section is provided to persons with whom it conducts business. Such notice may include, without limitation, posting notice in a conspicuous place in each of its offices.*
- 4. A governmental agency may require a person who records, files or otherwise submits any document to the governmental agency to provide an affirmation that the document does not contain personal information about any person or, if the document contains any such personal information, identification of the specific law, public program or grant that requires the inclusion of the personal information. A governmental agency may refuse to record, file or otherwise accept a document which does not contain such an affirmation when required or any document which contains personal information about a person that is not required to be included in the document pursuant to a specific state or federal law, for the administration of a public program or for an application for a federal or state grant.*
- 5. Each governmental agency may ensure that any personal information contained in a document that has been recorded, filed or otherwise submitted to the governmental agency before January 1, 2007, which the governmental agency continues to hold is:*
- (a) Maintained in a confidential manner if the personal information is required to be included in the document pursuant to a specific state or federal law, for the administration of a public program or for an application for a federal or state grant; or*
- (b) Obliterated or otherwise removed from the document, by any method, including, without limitation, through the use of computer software, if the personal information is not required to be*

included in the document pursuant to a specific state or federal law, for the administration of a public program or for an application for a federal or state grant.

↪ *Any action taken by a governmental agency pursuant to this subsection must not be construed as affecting the legality of the document.*

6. *A person may request that a governmental agency obliterate or otherwise remove from any document submitted by the person to the governmental agency before January 1, 2007, any personal information about the person contained in the document that is not required to be included in the document pursuant to a specific state or federal law, for the administration of a public program or for an application for a federal or state grant or, if the personal information is so required to be included in the document, the person may request that the governmental agency maintain the personal information in a confidential manner. If any documents that have been recorded, filed or otherwise submitted to a governmental agency:*

(a) *Are maintained in an electronic format that allows the governmental agency to retrieve components of personal information through the use of computer software, a request pursuant to this subsection must identify the components of personal information to be retrieved. The provisions of this paragraph do not require a governmental agency to purchase computer software to perform the service requested pursuant to this subsection.*

(b) *Are not maintained in an electronic format or not maintained in an electronic format in the manner described in paragraph (a), a request pursuant to this subsection must describe the document with sufficient specificity to enable the governmental agency to identify the document.*

↪ *The governmental agency shall not charge any fee to perform the service requested pursuant to this subsection.*

7. *As used in this section:*

(a) *“Governmental agency” means an officer, board, commission, department, division, bureau, district or any other unit of government of the State or a local government.*

(b) *“Personal information” has the meaning ascribed to it in [NRS 603A.040](#).*

Chapter 239 of the NRS provides general principles for the definition and the handling of public records. In particular, subsection 239.010.3 states that:

A governmental entity that has legal custody or control of a public book or record shall not deny a request made pursuant to subsection 1 to inspect or copy or receive a copy of a public book or record on the basis that the requested public book or record contains information that is confidential if the governmental entity can redact, delete, conceal or separate the confidential information from the information included in the public book or record that is not otherwise confidential.

Chapter 445B of the NRS (Air Controls) specifically provides further directions on what is confidential information and how such information must be handle in the context of the Air Program of the NDEP. In particular section 445B.570 – *Confidentiality and use of information obtained by Department*¹; penalty – states that (footnotes added for clarity):

¹ Nevada Department of Conservation and Natural Resources (DCNR)

1. *Any information which the Department obtains in the course of the performance of its duties pursuant to the provisions of this chapter is public information unless otherwise designated as confidential information pursuant to the provisions of this section.*
2. *The emission of an air contaminant which has an ambient air quality standard or emission standard or has been designated as a hazardous air pollutant by regulation of the Commission cannot be certified as being confidential.*
3. *Any confidential information received by the Commission², the Director³ or any local control authority which is certified in writing to the recipient as confidential by the owner or operator disclosing the information and verified and approved in writing as confidential by the recipient must, unless the owner expressly agrees to its publication or availability to the public, be used only:
 - (a) *In the administration or formulation of air pollution controls;*
 - (b) *In compiling or publishing analyses or summaries relating to the condition of the outdoor atmosphere which do not identify any owner or operator or reveal any confidential information;*or
 - (c) *In complying with federal statutes, rules and regulations.**
4. *This section does not prohibit the use of confidential information in a prosecution for the violation of any statute, ordinance or regulation for the control of air pollution.*
5. *A person who discloses or knowingly uses confidential information in violation of this section is guilty of a misdemeanor, and is liable in tort for any damages which may result from such disclosure or use.*
6. *As used in this section, "confidential information" means information or records which:
 - (a) *Relate to dollar amounts of production or sales;*
 - (b) *Relate to processes or production unique to the owner or operator; or*
 - (c) *If disclosed, would tend to affect adversely the competitive position of the owner or operator.**

² Nevada State Environmental Commission

³ Director of the Department of Conservation and Natural Resources

ATTACHMENT A

FUNDING REQUEST AND DIRECTION

ATTACHMENT B

**ELIGIBLE MITIGATION ACTION MANAGEMENT PLAN INCLUDING DETAILED
BUDGET AND IMPLEMENTATION AND EXPENDITURES TIMELINE**

ATTACHMENT B

PROJECT MANAGEMENT PLAN PROJECT SCHEDULE AND MILESTONES

Milestones	Date
NDEP begins solicitation for projects through the competitive Diesel Emission Mitigation Fund	CY 2021, Quarter 4
Project partner submits application to NDEP	CY 2022, Quarter 1
NDEP selects project partner for funding	CY 2022, Quarter 1
Project partner enters into Contracts, Purchase Orders, etc.	CY 2022, Quarter 2
Project partner enters into Subgrant Agreement with NDEP	CY 2022, Quarter 2
NDEP Semiannual Report Due	July 30, 2022
NDEP Semiannual Report Due	January 30, 2023
NDEP Semiannual Report Due	July 30, 2023
Project partner begins receiving new equipment	CY 2023, Quarter 4
Project partner begins scrapping old equipment	CY 2023, Quarter 4
NDEP Semiannual Report Due	January 30, 2024
Project partner completes receipt of new equipment	CY 2024, Quarter 1
Project partner completes scrapping of old equipment	CY 2024, Quarter 1
Project partner provides final invoice for equipment replacement to NDEP	CY 2024, Quarter 2
NDEP Submits and Trustee acknowledges receipt of project certification and funding direction	CY 2024, Quarter 2
Trustee acknowledges receipt of direction for payment	CY 2024, Quarter 2
Trustee completes project reimbursement	CY 2024, Quarter 2
NDEP Semiannual Report Due	July 30, 2024
NDEP reports project completion	July 30, 2024

PROJECT BUDGET

Budget Category	Admin Expenses	Share of Replacement Budget Funded by the Trust	Cost Share (Paid by Project Partner)	Subtotal
Equipment Expenditures				
Vehicle Replacement Cost: (1) Volvo Electric Semi-Truck	-	\$265,000.00	\$171,816.20	\$436,816.20
Subtotal for (1) electric semi-truck	-	\$265,000.00	\$171,816.20	\$436,816.20
Administrative Expenditures ¹				
Initial Payment Request	\$3,312.50			
Second Payment Request	\$3,312.50			
Third Payment Request	\$3,312.50			
Fourth Payment Request	\$3,312.50			
Final Payment Request	\$13,250.00			
Admin Expenditure Subtotal	\$26,500.00	-	-	\$26,500.00
Project Totals	\$26,500.00	\$265,000.00	\$171,816.20	\$463,316.20
Associated Percentages	10% of Trust's Total Cost	61% of Total Replacement Cost	39% of Total Replacement Cost	

¹ The NDEP is planning to submit four “Advancement” payment requests to the Trustee to support the NDEP’s Administrative expenses associated with this project and one “Reimbursement” payment request to the Trustee that will include direction to provide funding to the NDEP for Administrative expenses and to MGM Grand for the replacement of the semi-truck. The first “Advancement” request is included with this Beneficiary Eligible Mitigation Action Certification and the three that will follow are expected to be submitted on a semiannual basis beginning in 2023 – that is January 1, 2023, July 1, 2023, and January 1, 2024.

PROJECTED TRUST ALLOCATIONS

ANNUAL PROJECTIONS	2022	2023	2024
1. Anticipated annual project funding request to be paid through the Trust	\$ 3,312.50	\$ 6,625.00	\$ 281,562.50
2. Portion of anticipated project funding request to be paid through the Trust to cover Eligible Mitigation Action Administrative Expenditures	\$ 3,312.50	\$ 6,625.00	\$ 16,562.50
3. Portion of anticipated project funding request to be paid through the Trust to cover Eligible Mitigation Action Expenditures	-	-	\$ 265,000.00
4. Anticipated annual cost share	-	-	\$ 171,816.20
5. Anticipated total project funding by year (line 1 plus line 4)	\$ 3,312.50	\$ 6,625.00	\$ 453,378.70
CUMULATIVE PROJECTIONS			
6. Cumulative outstanding Trustee payments requested against cumulative approved Beneficiary allocation	\$ 8,822,481.59		
7. Cumulative Trustee payments made to date against cumulative approved Beneficiary allocation	\$ 12,079,440.45		
8. Beneficiary funding to be paid through the Trust for this project (sum of line 1)	\$ 291,500.00		
9. Total funding approved for Beneficiary Eligible Mitigation Actions, inclusive of current Action (sum of lines 6, 7, and 8)	\$ 21,193,422.03		
10. Beneficiary share of estimated funds remaining in Trust	\$ 13,924,030.00		
11. Estimated Beneficiary funds remaining in Trust after project completion (line 10 minus lines 6 and 8)	\$ 4,810,048.42		

ATTACHMENT C

**DETAILED PLAN FOR REPORTING ON ELIGIBLE MITIGATION ACTION
IMPLEMENTATION**

ATTACHMENT C

DETAILED PLAN FOR REPORTING ON ELIGIBLE MITIGATION ACTION IMPLEMENTATION

The Nevada Division of Environmental Protection (NDEP) will provide detailed reporting on this Volkswagen (VW) Environmental Mitigation Trust Fund for State Beneficiaries Eligible Mitigation Action project in two ways: 1, timely updates to NDEP's VW Environmental Mitigation Trust Fund webpage; and 2, Nevada's semiannual reporting obligation to Wilmington Trust (the "Trustee").

NDEP maintains a VW Environmental Mitigation Trust Fund specific webpage that has been designed to support public access and limit burden for the general public. The NDEP's VW specific webpage can currently be found at <https://ndep.nv.gov/air/vw-settlement>. Timely updates to the webpage will inform the general public on the project's status as well as when this Eligible Mitigation Action has been completed.

Subparagraph 5.3 of the Environmental Mitigation Trust Agreement for State Beneficiaries details Nevada's Reporting Obligations:

"For each Eligible Mitigation Action, no later than six months after receiving its first disbursement of Trust Assets, and thereafter no later than January 30 (for the preceding six-month period of July 1 to December 31) and July 30 (for the preceding six-month period of January 1 to June 30) of each year, each Beneficiary shall submit to the Trustee a semiannual report describing the progress implementing each Eligible Mitigation Action during the six-month period leading up to the reporting date (including a summary of all costs expended on the Eligible Mitigation Action through the reporting date). Such reports shall include a complete description of the status (including actual or projected termination date), development, implementation, and any modification of each approved Eligible Mitigation Action. Beneficiaries may group multiple Eligible Mitigation Actions and multiple sub-beneficiaries into a single report. These reports shall be signed by an official with the authority to submit the report for the Beneficiary and must contain an attestation that the information is true and correct and that the submission is made under penalty of perjury. To the extent a Beneficiary avails itself of the DERA Option described in Appendix D-2, that Beneficiary may submit its DERA Quarterly Programmatic Reports in satisfaction of its obligations under this Paragraph as to those Eligible Mitigation Actions funded through the DERA Option. The Trustee shall post each semiannual report on the State Trust's public-facing website upon receipt."

NDEP shall, in the next semiannual report following the Trustee's approval of this project, describe the progress implementing this Eligible Mitigation Action that will include a summary of all costs expended on the Eligible Mitigation Action through the reporting date. The report will also include a complete description of the status, development, implementation (including project schedule and milestone updates), and any modification to this Eligible Mitigation Action.

ATTACHMENT D

**DETAILED COST ESTIMATES FROM SELECTED OR POTENTIAL VENDORS FOR
EACH PROPOSED EXPENDITURE EXCEEDING \$25,000**



On behalf of Volvo Trucks and your partnering dealer, thank you for the opportunity to provide you with a quote!

PREPARED FOR

MGM RESORTS INT
3799 LAS VEGAS BLVD S
LAS VEGAS
NV 891094319

DATE

1/24/2022

PREPARED BY

TEC OF CALIFORNIA, INC.
4150 DONOVAN WAY
N. LAS VEGAS
NV 89030

QUOTE INFORMATION

TEC20220000315274D
VNRE42T300 Daycab - 113.5" BBC
Qty: 1

This proposal outlines the complete vehicle specification and performance details that have been customized to drive greater success for you and your business operations. The enclosed spec represents a solution that optimizes fuel efficiency, enhances driver productivity, provides peace of mind through our industry-leading active and passive safety features – all while ensuring your uptime to ultimately support your customers.

By partnering with your dealer and Volvo Trucks, you will benefit from innovative technologies that are incorporated in everything we do – from our powertrain components to connectivity solutions. We take our role as your business partner very seriously and appreciate the opportunity to support you with products and services that we hope will exceed your expectations. Our mission is to provide you with trucks and solutions that you can count on to help you be more successful and that you will be proud to own and operate.

Our responsibility doesn't stop when we hand over the keys. In fact, this is just the beginning of a great and close partnership. Just as you work hard to deliver to your customers, we will work hard to deliver on our promises to you.

As you review this proposal, please note any questions you may have so we can discuss them together. We hope you feel comfortable placing your trust in us, and look forward to doing business with you!

Sincerely,

DANNY FLAX

TEC OF CALIFORNIA, INC.

TECHNICAL SPECIFICATION

VNRE42T300 Daycab - 113.5" BBC

				WEIGHT (LB)		LIST PRICE USD
MODEL PACKAGE		DESCRIPTION		FRONT	REAR	
S	012215	MARKETING MODEL	VNRE42T300	0	0	0
S	99X76X	MANUFACTURING LOCATION	VOLVO TRUCKS - ASSEMBLED IN THE USA	0	0	0
S	007215	00 MODEL	NRE42T300	8,378	3,748	0
S	DDX10X	CHASSIS TYPE	TRACTOR	0	0	0
S	CDX15X	MODEL SERIES	VNR MODELS - 113.5" BBC	0	0	0
	MBT08T	VEHICLE CERTIFICATION	BATTERY ELECTRIC	0	0	0

				WEIGHT (LB)		LIST PRICE USD
VEHICLE ADAPTATION		DESCRIPTION		FRONT	REAR	
S	114010	MARKET ADAPTATION	USA / USA TERRITORY MARKET ADAPTATION	0	0	0
S	36XF1X	LANGUAGE ON DECALS	ENGLISH/SPANISH LANGUAGE ON DECALS	0	0	0
S	38XCNX	OPERATOR'S MANUAL LANGUAGE	ENGLISH	0	0	0
S	263004	VEHICLE APPLICATION	TRACTOR / DRY VAN TRAILER OR CONTAINER	0	0	0
S	DKXFSX	GROSS COMBINATION WEIGHT	66,000 LB GROSS COMBINATION WEIGHT	0	0	0
S	898002	VEHICLE WARRANTY QUALIFICATION	STANDARD NORMAL DUTY WARRANTY QUALIFIED	0	0	0
S	259002	VEHICLE VOCATION	PICKUP AND DELIVERY / SHORT HAUL SERVICE	0	0	0
	260001	OPERATING CONDITIONS	TURNPIKE / INTERSTATE, STARTING GRADES <8%	0	0	0
S	QCXA1X	TOPOGRAPHY	MOSTLY FLAT, MOST GRADES <3% (EX. OHIO)	0	0	0
S	E1BD1X	AMBIENT TEMPERATURE UPPER LIMIT	SUMMER AMBIENT TEMPERATURES DO NOT REGULARLY EXCEED 104 DEGREE F (40 DEGREE C)	0	0	0
S	264001	LOADING SURFACE FACTOR	CONCRETE LOADING AND / OR UNLOADING SURFACE	0	0	0
S	DHX10X	OPERATING CLASS	OPERATING CLASS ONE (ON HIGHWAY)	0	0	0
	938001	CUSTOMER FLEET SIZE	DEALER FLEET WITH LESS THAN 25 VEHICLES IN OWN FLEET OF ANY VEHICLE BRAND	0	0	0

				WEIGHT (LB)		LIST PRICE USD
PASSIVE AND ACTIVE SAFETY		DESCRIPTION		FRONT	REAR	
S	2CXD1X	CAB TYPE	300 - DAY CAB	0	0	0
S	DUXA1X	SRS AIR BAG	VOLVO SRS AIR BAG-DRIVER SIDE ONLY	0	0	0
S	43X40X	AUXILIARY DOWN VIEW MIRROR	DOWN VIEW MIRROR OVER PASSENGER DOOR	0	0	0
S	8ZDAAX	STABILITY CONTROL REGULATIONS	ELECTRONIC STABILITY CONTROL, REGULATION FMVSS	0	0	0
S	ZMXA1X	ESP PACKAGE	VOLVO ENHANCED STABILITY TECHNOLOGY (VEST)	0	0	0
S	WPXA1X	ABS TRACTION CONTROL	TRACTION CONTROL WITH LIMITED DISABLE	0	0	0
S	GCXJ6X	COLLISION AVOIDANCE SYSTEM	VOLVO ACTIVE DRIVER ASSIST (VADA 2.0)	12	0	0
S	5UCA1X	ACC OPTIONAL AUDIO FUNCTIONS	VADA 2.0 WARNING WITH VOLUME CONTROL	0	0	0
S	5VCB1X	VADA VOLUME CONTROL LEVEL	VADA 2.0 VOLUME LEVEL, MEDIUM	0	0	0
S	X6BA1X	VADA TIME GAP	VADA 2.0 DRIVER ADJUSTABLE TIME GAP (FOLLOWING DISTANCE)	0	0	0

TECHNICAL SPECIFICATION *(cont.)*

				WEIGHT (LB)		
PASSIVE AND ACTIVE SAFETY			DESCRIPTION	FRONT	REAR	LIST PRICE USD
S	G6CACX	ACC TIME GAP CONFIG SETTING	MEDIUM ALERT CONFIGURATION	0	0	0
S	70XA8X	LANE KEEPING SUPPORT SYSTEM	LANE DEPARTURE WARNING PLUS HIGHWAY DEPARTURE WARNING	5	0	467
S	2CEA1X	LANE SUP SYST DEACTIVATION	LANE KEEPING SUPPORT SYSTEM DEACTIVATION	0	0	0
S	2EEA1X	LANE DEPARTURE WARNING, OPTIONAL FEATURES	LANE DEPARTURE WARNING WITH VOLUME CONTROL	0	0	0
S	6HEE1X	LANE DEPARTURE WARNING SYSTEM VOLUME CONTROL LEVEL	LANE DEPARTURE WARNING SYSTEM VOLUME LEVEL, MEDIUM	0	0	0
S	5RXA1X	BACKUP ALARM	ELECTRIC BACKUP ALARM	0	3	0
S	3MBA1X	PARK BRAKE ALARM	PARK BRAKE ALARM, SOUNDS IF BRAKE OFF AND DRIVER'S DOOR OPENED	0	0	0

				WEIGHT (LB)		
ENGINE			DESCRIPTION	FRONT	REAR	LIST PRICE USD
S	1018K1	ENGINE PACKAGE	340 KW (455 HP) ELECTRIC MOTOR	0	0	0

				WEIGHT (LB)		
ENGINE EQUIPMENT			DESCRIPTION	FRONT	REAR	LIST PRICE USD
S	KWXA1X	AIR CLEANER	SINGLE STAGE AIR CLEANER	0	0	0
S	7LEE1X	AIR INTAKE COVER FINISH	AIR INTAKE COVER FINISH, BLACK	0	0	0
S	209014	RADIATOR COOLANT	EXTENDED LIFE ETHYLENE GLYCOL ANTI-FREEZE (RED), -34 F (-37 C), NO FILTER	0	0	0
S	D9EA1X	COOLING ENERGY STORAGE SYSTEM	COOLING ENERGY STORAGE SYSTEM, ACTIVE USING AN AC-COMPRESSOR	100	89	0
S	810154	BATTERY PACKAGE	2 BATTERIES, 170 AH	0	0	0
S	NFXZ1X	BATTERY DISCONNECT SWITCH	NO BATTERY DISCONNECT SWITCH PROVIDED	-2	0	0
S	KNXZ1X	EXHAUST SHIELD	NO EXHAUST SHIELD PROVIDED	0	-2	0
S	VWXAGX	COMPRESSOR	COMPRESSOR TYPE 360	0	0	0
S	B3FA8X	AIR COMPRESSOR DRIVING MOTOR	AIR COMPRESSOR DRIVING MOTOR, WATER COOLED	0	0	0
S	4HED1X	CHARGER INTERFACE CONNECTOR	CHARGER INTERFACE CONNECTOR, TYPE 1 (COMBO-1)	0	0	0
S	7GEH1X	CHARGING POWER	CHARGING POWER, 250 KW MAX	0	0	0
S	A4EAOX	ENERGY STORAGE SYSTEM CAPACITY	ESS TOTAL ENERGY 375 KWH (BOL)	0	0	0

				WEIGHT (LB)		
TRANSMISSION			DESCRIPTION	FRONT	REAR	LIST PRICE USD
S	270782	TRANSMISSION PACKAGE	VOLVO 2 SPEED I-SHIFT	0	0	0
S	RVXH2X	GEAR SHIFT CONTROL	GEAR SHIFT, DASH MOUNTED, BASIC, VOLVO I-SHIFT	0	0	0
S	3IAA2X	HILL START ASSIST	HILL START ASSIST	0	0	0
S	T2X99X	TRANSMISSION COOLER	NO TRANSMISSION COOLER PROVIDED	-22	-11	0
S	195103	DRIVELINE - MAIN	MERITOR RPL25HD W/PERMALUBE U-JOINTS (PROPS-L)	0	0	0
	THXE1X	DRIVELINE MANUFACTURER	MERITOR RPL SERIES DRIVELINE	133	131	0

TECHNICAL SPECIFICATION *(cont.)*

				WEIGHT (LB)		LIST PRICE USD
PROGRAMMABLE FEATURES		DESCRIPTION		FRONT	REAR	
S	JDXA1X	CRUISE CONTROL (AG)	WITH BASIC CRUISE CONTROL	0	0	0
	JFXLLX	CRUISE CONTROL, MAXIMUM SPEED (AI)	MAXIMUM CRUISE, 65 MPH (105 KM/H)	0	0	0
	JCXE6X	ROAD SPEED LIMIT SETTING (P1AOC)	ROAD SPEED LIMIT, 65 MPH (105 KM/H)	0	0	0
S	E3AAFX	CRUISE CONTROL MIN SPEED (BK)	MIN CRUISE, 35 MPH (56 KM/H)	0	0	0
S	X2BB1X	ROAD SPEED LIMIT CONTROL TYPE (P1I01)	WITH BASIC RSL CONTROL	0	0	0
S	R4BA1X	PRE-TRIP DIAGNOSTIC INSPECTION (JZU)	PRE-TRIP ASSISTANT	0	0	0

				WEIGHT (LB)		LIST PRICE USD
FRONT AXLE		DESCRIPTION		FRONT	REAR	
S	370401	FRONT AXLE PACKAGE	VOLVO VF12 12,500 LB FRONT SPRINGS	23	0	0
S	YNXB1X	FRONT STABILIZER	FRONT STABILIZER	86	0	0
S	70BC1X	BRAKE REGULATION	BRAKE REGULATION, STOPPING DISTANCE 250 FT (76M)	0	0	0
S	782012	FRONT BRAKE PACKAGE	FRONT BRAKE VOLVO, DISC, LIGHTWEIGHT	0	0	0
S	U5XF1X	FRONT BRAKE DIMENSION	17 INCH DIAMETER FRONT DISC BRAKE	0	0	0
S	U3XD1X	BRAKE TYPE, FRONT AXLE	LIGHTWEIGHT DISC FRONT AXLE BRAKE	0	0	0
S	LQXT4X	FRONT BRAKE LINING MATERIAL	BRAKE LINING MATERIAL, FRONT, TMD TX7400N	0	0	0
S	0KX11X	HUBS, FRONT AXLE	ALUMINIUM PRESET PLUS FRONT AXLE HUBS WITH SKF HUBCAPS	0	0	93
S	7VXB1X	FRONT AXLE LUBRICANT	SYNTHETIC FRONT AXLE LUBRICANT	0	0	0
S	XAXBFX	POWER STEERING GEAR	TRW THP60 INTEGRAL POWER STEERING GEAR	0	0	0
S	M0XB1X	STEERING SHAFT TYPE	GREASEABLE STEERING SHAFT	-2	0	0
S	371001	FRONT SUSPENSION PACKAGE	59" PARABOLIC LEAF FRONT SUSPENSION MATCHED TO FRONT AXLE CAPACITY	14	0	0
S	IRXA1X	FRONT SUSP MAINTENANCE	LUBRICATED SPRING PINS AND BUSHINGS	0	0	0

				WEIGHT (LB)		LIST PRICE USD
REAR AXLE		DESCRIPTION		FRONT	REAR	
S	330145	REAR AXLE PACKAGE	MERITOR RS 23-160 23,000 LB CAPACITY	0	0	0
	TAXHGX	REAR AXLE RATIO	4.30 REAR AXLE RATIO	0	0	0
S	TUXA1X	DIFFERENTIAL LOCK	FULL LOCKING WHEEL DIFFERENTIAL	0	64	0
S	350407	REAR SUSPENSION PACKAGE	20,000 LB VOLVO AIR SUSPENSION	0	0	0
S	YVXA1X	REAR SHOCK ABSORBER	SHOCK ABSORBERS, DRIVE AXLES	0	0	0
S	783019	REAR BRAKE PACKAGE	REAR BRAKE VOLVO DISC, LIGHTWEIGHT	0	0	0
S	U8XF1X	DRIVE AXLE BRAKE DIMENSION	17 INCH DIAMETER REAR DISC BRAKE	0	0	0
S	U4XD1X	BRAKE TYPE, DRIVE AXLE	LIGHTWEIGHT DISC DRIVE AXLE BRAKE	0	0	0
S	MAXT5X	DRIVE AXLE BRAKE LINING MATERIAL	BRAKE LINING MATERIAL, DRIVE, TMD TX7400N	0	0	0
S	0LX11X	HUBS, DRIVE AXLE	ALUMINIUM PRESET PLUS DRIVE AXLE HUB WITH INTEGRATED SPINDLE NUT	0	0	0

TECHNICAL SPECIFICATION *(cont.)*

				WEIGHT (LB)		LIST PRICE USD
REAR AXLE		DESCRIPTION		FRONT	REAR	
S	7WXADX	REAR AXLE LUBRICANT	CHEVRON DELO GEAR LUBRICANT ESI SAE 80W-90 (APPROVED FOR MERITOR EXTENDED COMPONENT WARRANTY)	0	0	0
S	781081	PARKING BRAKE CHAMBER PACKAGE	TWO PARK CHAMBERS WABCO DISC	0	0	0
S	V1AE3X	REAR BRAKE CHAMBER SIZE	REAR BRAKE CHAMBER 24 / 24 SQ INCHES (SERVICE / EMERGENCY)	0	0	0
S	UKXA1X	CHAMBER STROKE LENGTH, DRIVE AXLE	BASIC LENGTH BRAKE CHAMBER STROKE	0	0	0
S	784027	DRUM BRAKE SLACK ADJUSTERS	VOLVO DISC BRAKE FRONT AND REAR	0	0	0
S	O5BC3X	FRONT BRAKE CHAMBER SIZE	FRONT BRAKE CHAMBER 22 SQUARE INCHES (SERVICE)	0	0	0

				WEIGHT (LB)		LIST PRICE USD
CHASSIS		DESCRIPTION		FRONT	REAR	
	400169	WHEELBASE	169" WHEELBASE	219	217	0
S	402033	OVERHANG	33" OVERHANG	0	86	0
S	45XC1X	AERODYNAMIC DEVICE CAB SKIRT	CUSTOM CAB SKIRT	0	0	0
S	VHXEJX	AIR DRYER	MERITOR WABCO AIR DRYER, ELECTRONIC WITHOUT TURBO CUT OFF VALVE, WITH COALESCING OIL FILTER	-2	0	0
S	UWXD1X	AIR TANK DRAIN VALVE	MANUAL DRAIN VALVES, LANYARD ON WET TANK	0	0	0
S	403002	FRAME RAIL PACKAGE	10.47"X3.54"X.28" STRAIGHT STEEL RAILS	0	0	0
S	8EXA1X	INTERMEDIATE CROSSMEMBER MATERIAL	ALUMINUM CROSSMEMBER MATERIAL	14	14	0
S	X8XA1X	FORWARD REAR SUSP CROSSMEMBER MATERIAL	ALUMINUM CROSSMEMBER MATERIAL	0	-28	0
S	X6XB1X	REAR FRAME TREATMENT	TAPERED REAR CROSSMEMBER, 27 DEGREE	0	23	0
S	4DXA3X	FRONT BUMPER	STEEL AERO BUMPER W/END CAPS & AIR DAM	0	0	0
S	F7BA1X	BUMPER REINFORCEMENT	BUMPER REINFORCEMENT	23	0	0
S	68XE1X	REAR FENDER	RUBBER QUARTER FENDER	12	23	0
S	67XB1X	MUDFLAP TYPE, REAR AXLE	ANTI-SPRAY REAR MUDFLAP WITH LOGO	-6	23	0
S	69XF3X	MUDFLAP HANGERS, REAR AXLE	VOLVO PAINTED STEEL STRAIGHT	-8	27	0
	8QAC1X	REAR FENDER HEIGHT (CA)	BASIC REAR FENDER HEIGHT	0	0	0
S	5EXZ1X	PROTECTION PLATE, RADIATOR/OIL PAN	NO LOWER RADIATOR PROTECTION PROVIDED	-8	0	0
S	4EXB1X	FRONT TOWING DEVICE	TWO FRONT TOWING DEVICES	0	0	0
S	Q8CH1X	CHASSIS WIRING HARNESS CASING	HEAVY DUTY MAIN CHASSIS WIRING HARNESS COVERING	0	0	0

				WEIGHT (LB)		LIST PRICE USD
TRANSPORT ADAPTATION		DESCRIPTION		FRONT	REAR	
S	7KXA3X	BACK OF CAB (BOC) ACCESS PACKAGE	LEFT HAND BACK OF CAB ACCESS WITH 20" LOW PROFILE DECK	12	18	0
S	490314	FIFTH WHEEL PACKAGE	JOST AIR SLIDE LEFT HAND RELEASE	42	422	0
S	LPXC1X	FIFTH WHEEL GROUND STRAP	COILED FIFTH WHEEL GROUND STRAP	0	3	0
S	E5BATX	GROUND TO 5TH WHEEL TOP HGT.	48.5" FIFTH WHEEL HEIGHT	0	0	0
	6JXB1X	SLIDING FIFTH WHEEL TRAVEL	24.0 INCHES OF FIFTH WHEEL TRAVEL	3	18	113

TECHNICAL SPECIFICATION *(cont.)*

				WEIGHT (LB)		
TRANSPORT ADAPTATION		DESCRIPTION		FRONT	REAR	LIST PRICE USD
S	6BXZAX	FIFTH WHEEL REARMOST POSITION	0" AHEAD FORWARD DRIVE AXLE CENTER	0	0	0
S	LIXA1X	FIFTH WHEEL ANGLE MATERIAL	STEEL FIFTH WHEEL ANGLES	0	0	0
S	51XABX	HOSEHANGERS	TOWEL BAR WITH ADDITIONAL SPRING HANGER	0	0	0
S	WHXD1X	TRAILER BRAKE CONNECTION POSITION	CAB MOUNTED TRAILER BRAKE CONNECTION	0	0	0
S	52XB1X	TRAILER ELECTRICAL CABLE	DETACHABLE TRAILER CABLE	0	0	0
	5ZXC1X	TRAILER BRAKE HOSES & CABLES	12' STRAIGHT TRAILER BRAKE HOSES AND CABLE	0	0	-50
	WLXA1X	TRAILER BRAKE HAND CONTROL	FULL PRESSURE TRAILER BRAKE HAND CONTROL	3	0	73
S	6WXZ1X	CENTER CONSOLE FOR BODY CONTROLS	NO MOUNTING PLATE OR CONSOLE PROVIDED	-2	0	0

				WEIGHT (LB)		
CALCULATED CODES - KAX		DESCRIPTION		FRONT	REAR	LIST PRICE USD
S	9JXA1X	PROPCALC SELECTION	YES, THE ORDER MUST BE CALCULATED	0	0	0

				WEIGHT (LB)		
CAB EXTERIOR		DESCRIPTION		FRONT	REAR	LIST PRICE USD
	4RXZ1X	AERODYNAMIC DEVICE ROOF	NO ROOF AERODYNAMIC DEVICE PROVIDED	0	0	-860
S	4SXC1X	AERODYNAMIC DEVICE CAB SIDE	CAB SIDE FAIRINGS WITH EXTENDERS	23	27	0
S	2DX30X	CAB SUSPENSION	AIR RIDE CAB SUSPENSION WITH LATERAL DAMPENERS	-11	-2	0
S	21XA1X	AUXILIARY REAR WINDOW	STANDARD REAR WINDOW	0	0	0
S	WTXA1X	WINDSCREEN/HEATING	HEATED WINDSHIELD	0	0	0
S	D2XA1X	WIPER BLADES	WIPER BLADES	0	0	0
S	28XL1X	FRONT GRILLE	GREEN GRILLE	0	0	0
	3FX58X	EXTERIOR SIDE VIEW MIRRORS	CHROME AERODYNAMIC MIRRORS	0	0	92
S	3GXC1X	EXTERIOR MIRROR FEATURES	HEATED, POWER AXIS MIRROR, BOTH SIDES	3	0	0
	70AA1X	AUX.DIRECTIONAL INDICATOR LAMP	AUX.DIRECTIONAL INDICATOR LAMP, INTEGRATED LOWER CONVEX MIRR	0	0	151
S	87AAAX	MIRROR ARM WIND DEFLECTOR	INTEGRAL MIRROR ARM SHROUD AND A-PILLAR AIR-FLOW DEVICE	3	0	0
S	LZXD1X	AIR HORN	DUAL TRUMPET MOUNTED UNDER CAB	0	0	0
S	4NXB1X	EXTERIOR SUNVISOR	EXTERIOR SUN VISOR WITH CLEAR LENS LED MARKER LAMPS	0	0	0

				WEIGHT (LB)		
CAB INTERIOR		DESCRIPTION		FRONT	REAR	LIST PRICE USD
S	540091	INTERIOR TRIM PACKAGE	ELECTRIC EXPRESS - CLOTH PANELS WITH METAL HEX TRIM WITH INSTEP LAMP ON DOOR	0	0	0
S	1DAF1X	SEAT MFG. AND SERIES, DRIVER	NATIONAL DRIVER SEAT	0	0	0
S	15DA1X	SEAT PROFILE, DRIVER	STANDARD WIDTH DRIVER SEAT	0	0	0
S	520112	DRIVER SEAT	X6 WREN LEATHER / WREN CLOTH WITH GREEN ACCENT	12	0	0

TECHNICAL SPECIFICATION *(cont.)*

CAB INTERIOR			DESCRIPTION	WEIGHT (LB)		LIST PRICE USD
				FRONT	REAR	
S	3ZXJ3X	DRIVER SEAT SUPPORT	DRIVER SEAT - AIR SUSPENDED, ADJUSTABLE SHOCK, RIDE HEIGHT MEMORY, QUICK AIR RELEASE	0	0	0
S	I7DB4X	SEAT COMFORT, DRIVER	DRIVER SEAT - TWO AIR ADJUSTABLE LUMBAR CHAMBERS, SIDE BOLSTERS, BACK CYCLER MASSAGE	0	0	0
S	I9DB1X	SEAT CLIMATE, DRIVER	HEATED AND VENTILATED DRIVER SEAT	12	0	0
S	1GAF1X	SEAT MFG. & SERIES, PASSENGER	NATIONAL PASSENGER SEAT	0	0	0
S	I6DA1X	SEAT PROFILE, PASSENGER	STANDARD WIDTH PASSENGER SEAT	0	0	0
S	521112	PASSENGER SEAT	X6 WREN LEATHER / WREN CLOTH WITH GREEN ACCENT	49	0	0
S	34XK4X	PASSENGER SEAT SUPPORT	PASSENGER SEAT - AIR SUSPENDED,ADJUSTABLE SHOCK, RIDE HEIGHT MEMORY, QUICK AIR RELEASE	0	0	0
S	I8DB4X	SEAT COMFORT, PASSENGER	PASSENGER SEAT - TWO AIR ADJUSTABLE LUMBAR CHAMBERS, SIDE BOLSTERS, BACK CYCLER MASSAGE	0	0	0
S	J1DB1X	SEAT CLIMATE, PASSENGER	HEATED AND VENTILATED PASSENGER SEAT	12	0	0
S	3PXC1X	SEAT ARMREST	INBOARD DRIVER AND PASS SEAT ARMREST	7	0	0
S	K7AA1X	SAFETY BELT LENGTH	STANDARD SAFETY BELT LENGTH	0	0	0
S	OUXD1X	SAFETY BELT DRIVER SEAT	SEAT BELT DRIVER SEAT, LIME GREEN	0	0	0
S	OXXA7X	SAFETY BELT PASSENGER SEAT	SAFETY BELT PASSENGER SEAT, LIME GREEN	0	0	0
S	4AXC1X	CLIMATE UNIT	INTEGRAL AIR CONDITIONER WITH HEATER - ELECTRONIC CONTROLS	0	0	0
S	31XM2X	FLOOR MATS	FRONT FLOOR INSERTS, CARPET	-19	0	0
S	4JXD1X	STORAGE OVERHEAD DRIVER	NETTED OVERHEAD STORAGE (DRIVER / PASSENGER SIDES) WITH CB MOUNTING AND AUXILIARY SWITCHES	0	0	0
S	XRXD1X	STEERING WHEEL ADJUSTMENT	POSITION PERFECT STEERING WHEEL	3	0	0
S	7BAA6X	STEERING WHEEL MATERIAL	LEATHER WRAPPED STEERING WHEEL WITH ACCENT STITCHING	0	0	0
S	571023	GAUGE PACKAGE	VOLVO ELECTRIC VEHICLE INSTRUMENT CLUSTER	0	0	0
	M3AA1X	GAUGE, REAR AIR SUSP PRESSURE	REAR AIR SUSPENSION GAUGE	3	0	29
S	N8XD1X	SPEEDOMETER GRADUATION	MPH SPEEDOMETER GRADUATION	0	0	0

LIGHTING			DESCRIPTION	WEIGHT (LB)		LIST PRICE USD
				FRONT	REAR	
	N5XA1X	SPOTTING LAMP, BACK OF CAB	SINGLE BACK OF CAB SPOTTING LAMP, FLUSH MOUNTED	3	0	47
S	NGXB1X	FOG LAMPS	TWO FOG LAMPS - WHITE	7	-2	0
S	P8XB9X	HEADLAMPS	LED HEADLAMPS WITH SIGNATURE DRL	0	0	0
S	LSXG1X	DAYTIME RUNNING LAMPS	EQUIPPED WITH DAYTIME RUNNING LIGHTS	0	0	0
S	NEXH1X	STOP AND TAIL LIGHTS	DUAL INTEGRATED SUPER 60 LED TAIL LIGHTS, SEPARATE LED BACKUP LIGHT, ALL MTD IN TAPERED CROSSMEMBER	0	0	0
S	NPXB1X	TURN SIGNAL SWITCH	SELF CANCELLING TURN SIGNAL SWITCH	0	0	0

TECHNICAL SPECIFICATION *(cont.)*

				WEIGHT (LB)		
AUDIO SYSTEM			DESCRIPTION	FRONT	REAR	LIST PRICE USD
S	590031	RADIO PACKAGE	AM / FM / MP3 / USB / BLUETOOTH RADIO	0	0	0
S	73AF3X	RADIO ANTENNA	SINGLE RIGHT HAND 24 INCH MIRROR MOUNTED RADIO ANTENNA	0	0	0
S	LYXF1X	STEERING WHEEL CONTROLS	WITH STEERING WHEEL SWITCHES	3	0	0
S	N0XA1X	MARKER INTERRUPTER SWITCH	MARKER INTERRUPTER SWITCH	0	0	0
	5CXG1X	RADIO SPEAKERS	SPEAKERS IN DASHBOARD, DOOR, AND REAR CAB	0	5	78
S	5JXB1X	CB RADIO MOUNTING	OVERHEAD MOUNTED CB HOLD DOWN	0	0	0
S	5BXP1X	CB ANTENNA	SINGLE LEFT HAND 24 INCH MIRROR MOUNTED CB ANTENNA	0	0	0

				WEIGHT (LB)		
MISC CAB EQUIPMENT			DESCRIPTION	FRONT	REAR	LIST PRICE USD
S	2XX35X	WINDOW LIFT	POWER WINDOW LIFT BOTH DOORS	7	5	0
S	3AXC2X	DOOR LOCKS CAB	REMOTE CONTROL DOOR LOCK, BOTH DOORS	3	0	0
S	20XA1X	KEY TYPE	BASIC UNIQUE KEY	0	0	0
S	8BXB1X	KEY QUANTITY PER UNIT	4 KEYS PROVIDED PER UNIT	0	0	0
S	EAXA1X	AUXILIARY SWITCH	ONE (1) AUXILIARY SWITCH WITH WIRING, 15 AMP	0	0	0
S	40XAAX	FIRE EXTINGUISHER	2.6 POUND ABC DRY TYPE, RECHARGEABLE, MOUNTED IN CAB	3	0	0
S	4VX31X	AUXILIARY SAFETY EQUIPMENT	TRIANGLE REFLECTOR KIT	3	0	0

				WEIGHT (LB)		
TIRES AND WHEELS FRONT			DESCRIPTION	FRONT	REAR	LIST PRICE USD
S	0930D3	TIRE PACKAGE FRONT	295/75R22.5G BRIDGESTONE R213 ECOPIA (12350 LBS. GAWR) LONG / REGIONAL HAUL (Total for QTY = 2)	230	0	0
	4WCC1X	TIRE CLASSIFICATION FRONT (CA)	GHG FRONT TIRE CLASSIFICATION, LOW ROLLING RESISTANCE	0	0	0
S	084003	WHEEL PACKAGE FRONT	22.5X8.25 ACCURIDE ACCU-LITE POLISHED ALUMINUM 286BC HUB PILOTTED (Total for QTY = 2)	75	0	0
S	907002	FRONT WHEEL AND TIRE QUANTITY	TWO WHEELS AND TIRES FRONT	0	0	0

				WEIGHT (LB)		
TIRES AND WHEELS REAR			DESCRIPTION	FRONT	REAR	LIST PRICE USD
S	0940A1	TIRE PACKAGE DRIVE	295/75R22.5G BRIDGESTONE M713 ECOPIA (22700 LBS. GAWR) LONG / REGIONAL HAUL (Total for QTY = 4)	0	459	0
S	4XCA1X	TIRE CLASSIFICATION REAR (CA)	GHG REAR TIRE CLASSIFICATION, ADVANCED LOW ROLLING RESISTANCE	0	0	0
S	085003	WHEEL PACKAGE DRIVE	22.5X8.25 ACCURIDE ACCU-LITE POLISHED ALUMINUM 286BC HUB PILOTTED (Total for QTY = 4)	0	150	0
S	908004	DRIVE WHEEL AND TIRE QUANTITY	FOUR WHEELS AND TIRES DRIVE	0	0	0

TECHNICAL SPECIFICATION *(cont.)*

				WEIGHT (LB)		LIST PRICE USD
MISC TIRE EQUIPMENT		DESCRIPTION		FRONT	REAR	
S	15XABX	TIRE INFLATION VALVE	TIRE INFLATION VALVE, STANDARD	0	0	0

				WEIGHT (LB)		LIST PRICE USD
PAINT		DESCRIPTION		FRONT	REAR	
S	950800	CAB PAINT SCHEME	SINGLE COLOR PAINT	0	0	0
S	9808X0	FIRST TRUCK COLOR	ELECTRIC GREEN; CAE289	0	0	0
S	MPB980	CAB COLOR	CAB SAME AS FIRST COLOR	0	0	0
S	MPD980	HOOD COLOR	HOOD SAME AS FIRST COLOR	0	0	0
S	MPE980	COWL COLOR	COWL SAME AS FIRST COLOR	0	0	0
S	MPC998	SLEEPER ROOF COLOR	NO SLEEPER ROOF COLOR	0	0	0
S	987980	BUMPER COLOR	BUMPER SAME AS FIRST COLOR	0	0	0
S	994998	ROOF FAIRING COLOR	NO ROOF FAIRING COLOR PROVIDED	0	0	0
S	996980	SUN VISOR COLOR	SUN VISOR SAME AS FIRST COLOR	0	0	0
S	9861U1	CHASSIS COLOR	BLACK P3036	0	0	0
S	988401	DISC WHEEL OR RIM COLOR	STEEL DISC WHEELS - PREPAINTED WHITE, POWDER - COAT, ALUMINUM OR STYLIZED DISC - UNPAINTED	0	0	0

				WEIGHT (LB)		LIST PRICE USD
BUSINESS SERVICES		DESCRIPTION		FRONT	REAR	
S	9LAA1X	PRE-DELIVERY INSPECTION	PRE-DELIVERY INSPECTION, BASIC	0	0	0

				WEIGHT (LB)		LIST PRICE USD
OUTSIDE MODIFICATION PLANNING		DESCRIPTION		FRONT	REAR	
S	615998	FONTAINE IN-SERVICE PLANNING CODE	NO FONTAINE IN-SERVICE PLANNING CODE	0	0	0
S	609998	FONTAINE LEAD TIME CODE	NO FONTAINE LEAD TIME	0	0	0

				WEIGHT (LB)		LIST PRICE USD
BASE WARRANTY AND PURCHASED COVERAGES		DESCRIPTION		FRONT	REAR	
	871019	SERVICE CONTRACT	EV GOLD CONTRACT 60/250K; 4 BATTERY	0	0	18,795
S	872010	ELECTRIC CONTROL SYSTEM	36 MO/150K MILES - BASE ELECTRIC CONTROL SYSTEM COVERAGE	0	0	0
S	877010	ELECTRIC POWERTRAIN	36 MO/150K MILES - BASE ELECTRIC POWERTRAIN COVERAGE	0	0	0
S	879010	BATTERY - ELECTRIC TRUCK	36 MO/150K MILES - BASE BATTERY COVERAGE	0	0	0
S	899874	WARRANTY TYPE	ELECTRIC TRUCK BASE CHASSIS PLAN	0	0	0
S	888606	ADDITIONAL EXTENDED CHASSIS TOWING COVERAGE	BASE CHASSIS TOWING COVERAGE, ELECTRIC TRUCK, 12 MO/100K MILES	0	0	0
S	874903	ADDITIONAL EXTENDED ENGINE TOWING COVERAGE	ELECTRIC CONTROL SYSTEM & ELECTRIC POWERTRAIN TOWING, 36 MO/150K MILES	0	0	0
S	959998	NEW PAINT DEVELOPMENT FEE	NO NEW PAINT DEVELOPMENT FEE	0	0	0
S	866022	REMOTE DIAGNOSTICS BUNDLE	REMOTE DIAGNOSTICS - ELECTRIC TRUCK PLACE HOLDER	0	0	0
S	867009	UPTIME CENTER BUNDLE	ASIST AND VOLVO ACTION SERVICE - ELECTRIC TRUCK PLACE HOLDER	0	0	0

TECHNICAL SPECIFICATION *(cont.)*

ADDITIONAL ENGINEERING (Non Approved)	DESCRIPTION	WEIGHT (LB)		LIST PRICE USD
		FRONT	REAR	
CA 1		0	0	0
FRONT / REAR AXLE WEIGHTS (LB)		9430	5497	
TOTAL WEIGHT (LB)		14,926		

PRICING SUMMARY

VNRE42T300 Daycab - 113.5" BBC

VEHICLE PRICE

\$345,943.00

SOFT OFFERS AND WARRANTY

EV GOLD CONTRACT 60/250K; 4 BATTERY

\$18,795.00

TOTAL SOFT OFFERS AND WARRANTY

\$18,795.00

TAX SUMMARY

AMT. SUBJECT TO TAX

FET (12%)

\$345,943.00

\$41,513.16

NV Sales Tax (8.38%)

\$364,738.00

\$30,565.04

TOTAL TAX

\$72,078.20

TOTAL SELLING PRICE (PER UNIT) USD

\$436,816.20

MGM RESORTS INT

DATE

TEC OF CALIFORNIA, INC.

DATE

VEHICLE SPECIFICATION/CALCULATED PERFORMANCE SUMMARY

Description	Sales Code	Dwg Ref	Length	UOM
Front Frame Extension	N/A	FE	0.0	INCHES
Bumper to Front Axle	N/A	BA	51.1	INCHES
Wheelbase	N/A	WB	169.3	INCHES
Rear Overhang	N/A	OH	33.3	INCHES
Overall Length	N/A	OL	253.7	INCHES
Bumper to Back of Cab	N/A	BBC	113.5	INCHES
Eff. Bumper to Back of Cab	N/A	EBBC	143.5	INCHES
Eff. Cab to Rear Axle	N/A	ECA	76.9	INCHES
Eff. Front Axle to Back of Cab	N/A	EAC	92.4	INCHES
Eff. Cab to End of Frame	N/A	ECEF	110.2	INCHES
Unladen 5th Wheel Height	E5BATX	5W	48.5	INCHES
Unladen Frame Height	N/A	FH	39.0	INCHES
Cab Height	N/A	CH	75.0	INCHES
Overall Height	N/A	OVH	114.0	INCHES
Driver CG	N/A	DCG	42.0	INCHES
Second Front Axle Spacing		SFAS	0.0	INCHES

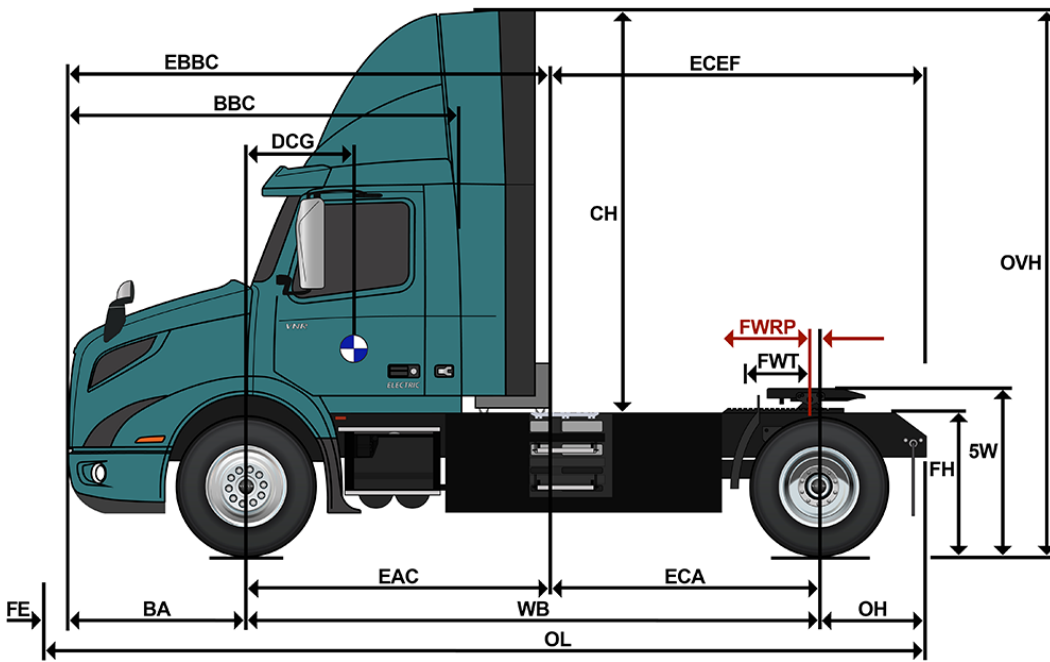

VEHICLE SPECIFICATION/CALCULATED PERFORMANCE SUMMARY

Description	Sales Code	Dwg Ref	Left Value(in)	Right Value(in)
Wheelbase	N/A	WB	169.3	169.3
Available Rail Space Right	N/A	ARSR	N/A	10168.3
Available Rail Space Left	N/A	ARSL	10168.3	N/A
Eff. Front Axle to Back of Cab	N/A	EAC	92.4	92.4

Top View image is intended for illustration purposes only and is not presented to scale. Wheelbase, Axle Spacing and After frame are not shown as specified, but are a representation. Customer Adaptation (CA) options and relocated components are not represented in these images. Most CA options impact the variation of the image, thus an image may not populate. Calculations are approximate to a tolerance of ± 4 inches due to component mounting variation. Certain chassis component options are NOT represented in the Top View image, such as, but not exclusive to, Front Frame Extensions, Fuel Water Separators, Air Dryers, PTOs, Fifth Wheels, Chassis Fairings, Toolboxes, Trailer Connections. For further information on these items and their respective locations on your specification, please refer to the data sheets associated with those items in the configurator.

VEHICLE SPECIFICATION/CALCULATED PERFORMANCE SUMMARY

Description	Sales Code	Dwg Ref	Rear		UOM
			Unladen	Laden	
Requested Fifth Wheel Height	E5BATX		48.5	48.5	INCHES
Tire Radius	0940A1	A	20.2	18.9	INCHES
Suspension Height	350407	B	8.3	8.0	INCHES
Frame Depth	403002	C	10.5	10.5	INCHES
Closest Available Fifth Wheel Leg Height	N/A	D	0.0	0.0	INCHES
Total Height	N/A	E	39.0	37.4	INCHES

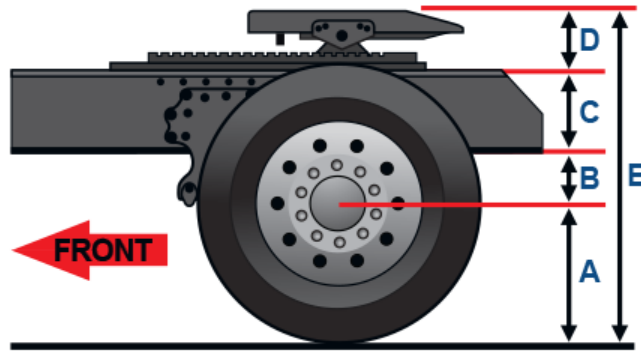

VEHICLE SPECIFICATION/CALCULATED PERFORMANCE SUMMARY

Description	Sales Code	Dwg Ref	Length	UOM
SAE Turning Radius	N/A	A*	23.7	FEET
Adjusted Turning Radius	N/A	A	24.3	FEET
Curb-to-Curb Diameter	N/A	B	49.5	FEET
Wall-to-Wall Diameter	N/A	C	54.5	FEET

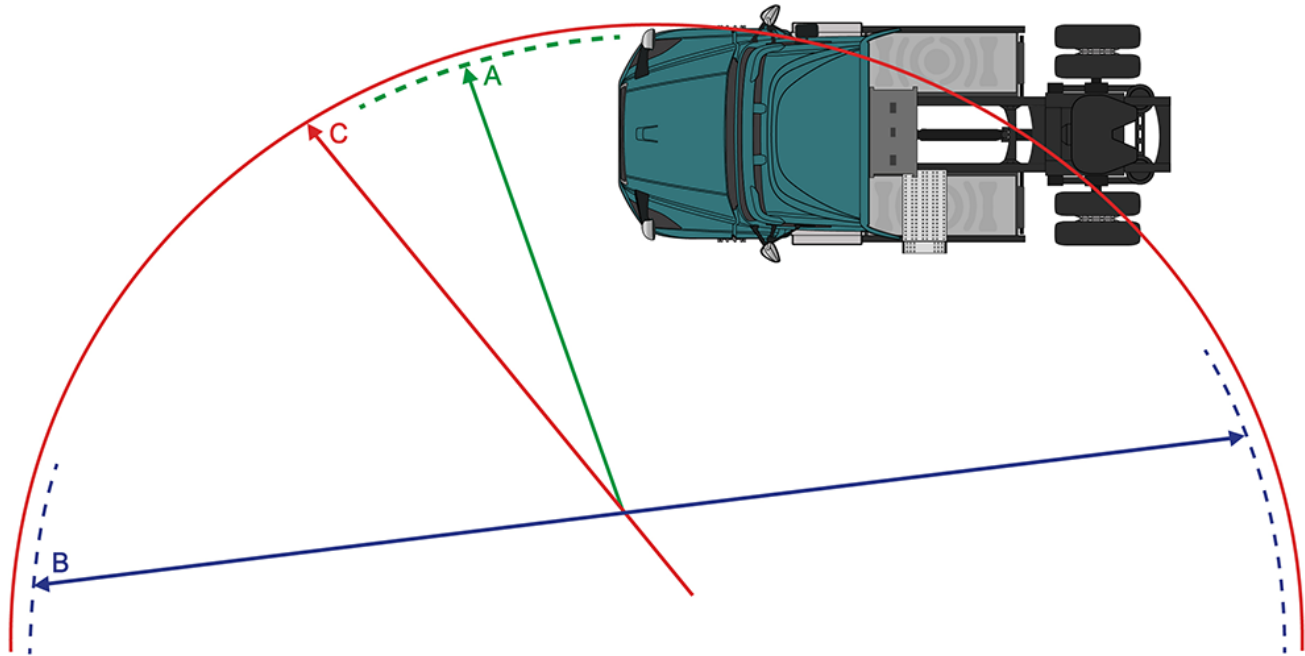

Tests have shown that the true location of the turning center is further to the rear than midway between drive axle sets (where applicable)

The actual location of the turning center depends on:

- Whether the drive tire equipment is single or dual.
- The overall load distribution for the vehicle (front/rear, between drive axles) in a loaded condition
- Manufacturing tolerances within the steering components



Volvo Trucks

www.volvotrucks.us | www.volvotrucks.ca