

BENEFICIARY ELIGIBLE MITIGATION ACTION CERTIFICATION

Beneficiary _____

Lead Agency Authorized to Act on Behalf of the Beneficiary Nevada Division of Environmental Protection
(Any authorized person with delegation of such authority to direct the Trustee delivered to the Trustee pursuant to a Delegation of Authority and Certificate of Incumbency)

Action Title:	
Beneficiary’s Project ID:	
Funding Request No.	<i>(sequential)</i>
Request Type: (select one or more)	<input type="checkbox"/> Reimbursement <input type="checkbox"/> Advance <input type="checkbox"/> Other (specify): _____
Payment to be made to: (select one or more)	<input type="checkbox"/> Beneficiary <input type="checkbox"/> Other (specify): _____
Funding Request & Direction (Attachment A)	<input type="checkbox"/> Attached to this Certification <input type="checkbox"/> To be Provided Separately

SUMMARY

Eligible Mitigation Action <input type="checkbox"/> Appendix D-2 item (specify): _____ Action Type <input type="checkbox"/> Item 10 - DERA Option (5.2.12) (specify and attach DERA Proposal): _____												
Explanation of how funding request fits into Beneficiary’s Mitigation Plan (5.2.1): Detailed on pages 10-17 of Nevada’s BMP, this funding request will support multiple AGSE replacements.												
Detailed Description of Mitigation Action Item Including Community and Air Quality Benefits (5.2.2): Please refer to attached pages 4-8 for this description.												
Estimate of Anticipated NOx Reductions (5.2.3): It is anticipated that this project will mitigate 14.069 tons NOx.												
Identification of Governmental Entity Responsible for Reviewing and Auditing Expenditures of Eligible Mitigation Action Funds to Ensure Compliance with Applicable Law (5.2.7.1): The Nevada Division of Environmental Protection												
Describe how the Beneficiary will make documentation publicly available (5.2.7.2). Please refer to attached pages 9-12 of this submittal for this description.												
Describe any cost share requirement to be placed on each NOx source proposed to be mitigated (5.2.8). <table border="0" style="width: 100%;"> <tr> <td>Total Project Budget:</td> <td>Project Costs paid by Trust:</td> <td>Cost share requirement:</td> </tr> <tr> <td>\$2,306,777.33</td> <td>Category 7 Funds</td> <td>\$1,073,169.78</td> </tr> <tr> <td></td> <td>Project Admin Costs</td> <td></td> </tr> <tr> <td></td> <td>\$1,072,702.22</td> <td>\$160,905.33</td> </tr> </table>	Total Project Budget:	Project Costs paid by Trust:	Cost share requirement:	\$2,306,777.33	Category 7 Funds	\$1,073,169.78		Project Admin Costs			\$1,072,702.22	\$160,905.33
Total Project Budget:	Project Costs paid by Trust:	Cost share requirement:										
\$2,306,777.33	Category 7 Funds	\$1,073,169.78										
	Project Admin Costs											
	\$1,072,702.22	\$160,905.33										
Describe how the Beneficiary complied with subparagraph 4.2.8, related to notice to U.S. Government Agencies (5.2.9). NDEP sent emails to the representatives from the U.S. Department of the Interior and the U.S. Department of Agriculture listed in subparagraph 4.2.8 of the State Trust Agreement on February 23, 2018.												

If applicable, describe how the mitigation action will mitigate the impacts of NOx emissions on communities that have historically borne a disproportionate share of the adverse impacts of such emissions (5.2.10).
This airport ground support equipment replacement project will occur in Clark County, Nevada. Clark County is an area of Nevada that has historically borne a disproportionate share of the State's air pollution burden.

ATTACHMENTS
(CHECK BOX IF ATTACHED)

- Attachment A** **Funding Request and Direction.**
- Attachment B** **Eligible Mitigation Action Management Plan Including Detailed Budget and Implementation and Expenditures Timeline (5.2.4).**
- Attachment C** **Detailed Plan for Reporting on Eligible Mitigation Action Implementation (5.2.11).**
- Attachment D** **Detailed cost estimates from selected or potential vendors for each proposed expenditure exceeding \$25,000 (5.2.6). [Attach only if project involves vendor expenditures exceeding \$25,000.]**
- Attachment E** **DERA Option (5.2.12). [Attach only if using DERA option.]**
- Attachment F** **Attachment specifying amount of requested funding to be debited against each beneficiary's allocation (5.2.13). [Attach only if this is a joint application involving multiple beneficiaries.]**

CERTIFICATIONS

By submitting this application, the Lead Agency makes the following certifications:

- 1. This application is submitted on behalf of Beneficiary Nevada, and the person executing this certification has authority to make this certification on behalf of the Lead Agency and Beneficiary, pursuant to the Certification for Beneficiary Status filed with the Court.**
- 2. Beneficiary requests and directs that the Trustee make the payments described in this application and Attachment A to this Form.**
- 3. This application contains all information and certifications required by Paragraph 5.2 of the Trust Agreement, and the Trustee may rely on this application, Attachment A, and related certifications in making disbursements of trust funds for the aforementioned Project ID.**
- 4. Any vendors were or will be selected in accordance with a jurisdiction's public contracting law as applicable. (5.2.5)**
- 5. Beneficiary will maintain and make publicly available all documentation submitted in**

support of this funding request and all records supporting all expenditures of eligible mitigation action funds subject to applicable laws governing the publication of confidential business information and personally identifiable information. (5.2.7.2)

DATED: 8/30/2022

Danilo Dragoni, PhD

[NAME]



[SIGNATURE]

Chief, Bureau of Air Quality Planning

[TITLE]

Nevada Division of Environmental Protection

[LEAD AGENCY]

for

Nevada

[BENEFICIARY]

DETAILED DESCRIPTION OF MITIGATION ACTION ITEM INCLUDING COMMUNITY AND AIR QUALITY BENEFITS (5.2.2)

This Eligible Mitigation Action Category 7 – Airport Ground Support Equipment replacement project will support the early retirement and replacement of 8 pieces of airport ground support equipment (AGSE) owned and operated by Southwest Airlines and will be located at the McCarran International Airport in Clark County, Nevada. Upon completion of the project, the permanent scrapping of the diesel-powered, Non-Government owned AGSE for brand new, all-electric replacements will provide a direct benefit to air quality.

The details regarding the individual units being replaced through this project as well as the replacement units are included on pages 5 and 6 of this submission. The Nevada Division of Environmental Protection (NDEP) will work with Southwest Airlines on the scrapping of the AGSE and will routinely coordinate with their staff for routine updates and possible site visits to ensure a timely and efficient completion of this project. The NDEP will not seek to have Southwest Airlines reimbursed for this project until they have provided sufficient scrapping evidence to the NDEP.

The total, expected lifetime emissions reductions are provided in the table below (and detailed on page 7). Emissions reductions were calculated based on the approach for alternative fuel/all-electric replacements that the NDEP identified on page 26 of our Beneficiary Mitigation Plan.¹ Emissions reductions were quantified using the EPA’s Diesel Emission Quantifier.²

Pollutant	Emissions Reductions (tons)
NOx	14.409
PM _{2.5}	1.123
CO	7.873
HC	1.922
CO ₂	3,712.448

August 22, 2022 Revision

Southwest Airlines is requesting to add an additional 8 pieces of AGSE to their scope of work without requesting additional funds. This will bring the total equipment replaced from 8 to 16 and they will instead purchase a less expensive electric version than previously announced. This addition will not greatly affect the NOx emission reductions for this project due to the change in schedule from the COVID-19 pandemic. The timeline for project completion will not be affected. Please note that McCarran International Airport has been renamed Harry Reid International Airport. Details regarding the individual units being replaced through this project as well as the replacement units are included on pages 5-8 of this submission. Detailed lifetime emission reductions are provided on page 8.

Pollutant	Emissions Reductions (tons)
NOx	14.069
PM _{2.5}	0.946
CO	5.18
HC	1.002
CO ₂	6,103.44

¹ Nevada’s Beneficiary Mitigation Plan can be found online at https://ndep.nv.gov/uploads/air-vw-bmp-docs/beneficiary_mitigation_plan.pdf.

² The EPA’s Diesel Emission Quantifier can be found online at <https://cfpub.epa.gov/quantifier/index.cfm?action=main.home>.

Existing Equipment/Engine Information		
Fleet Information	Unit 1	Unit 2
Southwest Unit Number	3976	425
What is the equipment's intended use?	Aircraft Tug	Aircraft Tug
Equipment Manufacturer	Equi Tech	FMC
Equipment Model	MB4 200	B-300
Equipment Model Year	1985	1996
Engine Make	Perkins	Detroit
Engine Model	4.236	353T
Engine Model Year	1985	1996
Engine Serial Number	LJ70128U934521K	03D0300986
Engine Horsepower	81	136
Annual Hours of Operation	357	317
Total Hours of Operation	12138	7291
Fuel Type	Diesel	Diesel
Annual Fuel Used	896	1326
If diesel-powered, what is the engine tier?	0	0
Remaining Equipment Life	1	4
Normal Attrition Year	2016	2027
Replacement/Repower Equipment/Engine Information		
Fleet Information	Unit 1	Unit 2
Equipment GVWR	27006	27006
Equipment Make	TLD	TLD
Equipment Model	TMX-150-e	TMX-150-e
Equipment Model Year	2022	2022
Engine Make	ABM	ABM
Engine Model	27KW	27KW
Engine Model Year	2022	2022
Fuel Type	Electric	Electric
Unit Replacement/Repower Cost	\$134,117	\$134,117

Unit 3	Unit 4	Unit 5	Unit 6	Unit 7	Unit 8	Unit 9
989	992	1169	979	987	1843	2821
Aircraft Tug	Aircraft Tug	Aircraft Tug	Aircraft Tug	Aircraft Tug	Aircraft Tug	Aircraft Tug
FMC	FMC	FMC	Jetline	Jetline	Jetline	FMC
B-300	B-350	B-300	B-300	B-300	B-300	B-350
1996	1998	1994	1994	1994	1995	2000
Detroit	Deutz	Detroit	Detroit	Detroit	Detroit	Deutz
353T	BF4M1013F	453	453	353T	353	BF4M 1013
1996	1998	1994	1994	1994	1995	2000
03D0300465	00323993	53PF022303	04D0230092	03D0213072	03D0213215	00515677
150	125	123	123	150	136	125
402	378	418	357	342	320	290
9246	7938	10450	8925	8550	7680	5756
Diesel	Diesel	Diesel	Diesel	Diesel	Diesel	Diesel
1681	1317	1433	1224	1430	1338	1011
0	0	0	0	0	0	1
4	6	2	2	2	3	8
2027	2029	2025	2025	2025	2026	2031

Unit 3	Unit 4	Unit 5	Unit 6	Unit 7	Unit 8	Unit 9
27006	27006	27006	27006	27006	27006	27006
TLD	TLD	TLD	TLD	TLD	TLD	TLD
TMX-150-e	TMX-150-e	TMX-150-e	TMX-150-e	TMX-150-e	TMX-150-e	TMX-150-e
2022	2022	2022	2022	2022	2022	2022
ABM	ABM	ABM	ABM	ABM	ABM	ABM
27KW	27KW	27KW	27KW	27KW	27KW	27KW
2022	2022	2022	2022	2022	2022	2022
Electric	Electric	Electric	Electric	Electric	Electric	Electric
\$134,117	\$134,117	\$134,117	\$134,117	\$134,117	\$134,117	\$134,117

Unit 10	Unit 11	Unit 12	Unit 13	Unit 14	Unit 15	Unit 16
3452	981	984	990	991	993	994
Aircraft Tug	Aircraft Tug	Aircraft Tug	Aircraft Tug	Aircraft Tug	Aircraft Tug	Aircraft Tug
FMC	FMC	FMC	FMC	FMC	FMC	FMC
B-350	B-350	B-350	B-350	B-350	B-350	B-350
2000	1999	1999	1998	1998	2000	2000
Deutz	Deutz	Deutz	Deutz	Deutz	Deutz	Deutz
BF4M 1013	BF4M 1013F	BF4M 1013F	BF4M 1013F	BF4M1013F	BF4M1013F	BF4M1013F
2000	1999	1999	1998	1998	2000	2000
00532268	00315703	00419585	00261006	00269138	00483857	00532265
125	125	125	125	125	125	125
273	247	223	245	225	224	232
9204	4870	2578	2628	1745	5234	4038
Diesel	Diesel	Diesel	Diesel	Diesel	Diesel	Diesel
951	861	777	854	784	781	808
1	1	1	1	1	1	1
8	7	7	6	6	8	8
2031	2030	2030	2029	2029	2031	2031
Unit 10	Unit 11	Unit 12	Unit 13	Unit 14	Unit 15	Unit 16
27006	27006	27006	27006	27006	27006	27006
TLD	TLD	TLD	TLD	TLD	TLD	TLD
TMX-150-e	TMX-150-e	TMX-150-e	TMX-150-e	TMX-150-e	TMX-150-e	TMX-150-e
2022	2022	2022	2022	2022	2022	2022
ABM	ABM	ABM	ABM	ABM	ABM	ABM
27KW	27KW	27KW	27KW	27KW	27KW	27KW
2022	2022	2022	2022	2022	2022	2022
Electric	Electric	Electric	Electric	Electric	Electric	Electric
\$134,117	\$134,117	\$134,117	\$134,117	\$134,117	\$134,117	\$134,117

	Unit Cost	Requested Amount	AFLEET or DEQ or Gas	Emissions Reductions (tons)				
				NOx	PM2.5	CO	HC	CO2
Unit 1	\$134,117.00	\$67,043.89	DEQ	1.510	0.080	0.296	0.072	401.378
Unit 2	\$134,117.00	\$67,043.89	DEQ	0.672	0.048	0.361	0.056	435.015
Unit 3	\$134,117.00	\$67,043.89	DEQ	0.642	0.044	0.327	0.051	538.144
Unit 4	\$134,117.00	\$67,043.89	DEQ	0.672	0.048	0.361	0.056	402.581
Unit 5	\$134,117.00	\$67,043.89	DEQ	0.854	0.061	0.459	0.071	512.674
Unit 6	\$134,117.00	\$67,043.89	DEQ	1.172	0.079	0.309	0.076	490.320
Unit 7	\$134,117.00	\$67,043.89	DEQ	1.133	0.074	0.298	0.073	552.128
Unit 8	\$134,117.00	\$67,043.89	DEQ	0.901	0.058	0.236	0.058	489.274
Unit 9	\$134,117.00	\$67,043.89	DEQ	0.783	0.050	0.204	0.051	322.785
Unit 10	\$134,117.00	\$67,043.89	DEQ	0.739	0.049	0.194	0.048	303.716
Unit 11	\$134,117.00	\$67,043.89	DEQ	0.680	0.044	0.178	0.044	285.390
Unit 12	\$134,117.00	\$67,043.89	DEQ	0.867	0.055	0.225	0.056	280.080
Unit 13	\$134,117.00	\$67,043.89	DEQ	0.906	0.058	0.236	0.059	312.908
Unit 14	\$134,117.00	\$67,043.89	DEQ	0.203	0.026	0.140	0.024	230.580
Unit 15	\$134,117.00	\$67,043.88	DEQ	0.984	0.073	0.568	0.087	261.754
Unit 16	\$134,117.00	\$67,043.88	DEQ	1.351	0.101	0.787	0.121	284.715
Total	\$2,145,872.00	\$1,072,702.22		14.069	0.946	5.180	1.002	6,103.440

ATTACHMENT FOR 5.2.7.2

Describe how the Beneficiary will make documentation publicly available

Subparagraph 5.2.7.2 of the Environmental Mitigation Trust Agreement for State Beneficiaries requires that Beneficiaries include in their funding requests:

A commitment by the Beneficiary to maintain and make publicly available all documentation submitted in support of the funding request and all records supporting all expenditures of Eligible Mitigation Action funds, subject to applicable laws governing the publication of confidential business information and personally identifiable information, together with an explanation of the procedures by which the Beneficiary shall make such documentation publicly available;

The Nevada Division of Environmental Protection (NDEP), the Lead Agency for the State of Nevada, is committed to maintaining and making publicly available all documentation submitted support of the funding requests and all records supporting all expenditures of Eligible Mitigation Action funds, subject to applicable laws governing the publication of confidential business information and personally identifiable information.

The public will be able to view these records on the NDEP's website (<https://ndep.nv.gov>). The NDEP will maintain these records on a Volkswagen (VW) Environmental Mitigation Trust Fund specific webpage that will be designed to support public access and limit burden for the general public. The NDEP's VW specific webpage can currently be found at <https://ndep.nv.gov/air/vw-settlement>.

The NDEP has created an electronic listserv, open to the public, used to communicate news, events, and information related the Environmental Mitigation Trust Fund (Mitigation Fund). The listserv, NevadaVWFund, is advertised through the NDEP website and at public events related to the Mitigation Fund.

Chapters 603A and 239B of the Nevada Revised Statutes (NRS) provide definitions and requirements for handling *personal information*.

NRS Section 603A.040 defines 'Personal Information' as:

1. *"Personal information" means a natural person's first name or first initial and last name in combination with any one or more of the following data elements, when the name and data elements are not encrypted:*
 - (a) *Social security number.*
 - (b) *Driver's license number, driver authorization card number or identification card number.*
 - (c) *Account number, credit card number or debit card number, in combination with any required security code, access code or password that would permit access to the person's financial account.*
 - (d) *A medical identification number or a health insurance identification number.*

- (e) A user name, unique identifier or electronic mail address in combination with a password, access code or security question and answer that would permit access to an online account.*
- 2. The term does not include the last four digits of a social security number, the last four digits of a driver's license number, the last four digits of a driver authorization card number or the last four digits of an identification card number or publicly available information that is lawfully made available to the general public from federal, state or local governmental records.*

NRS Section 239B.030 – *Recorded, filed or otherwise submitted documents* - states that:

- 1. Except as otherwise provided in subsections 2 and 6, a person shall not include and a governmental agency shall not require a person to include any personal information about a person on any document that is recorded, filed or otherwise submitted to the governmental agency on or after January 1, 2007.*
- 2. If personal information about a person is required to be included in a document that is recorded, filed or otherwise submitted to a governmental agency on or after January 1, 2007, pursuant to a specific state or federal law, for the administration of a public program or for an application for a federal or state grant, a governmental agency shall ensure that the personal information is maintained in a confidential manner and may only disclose the personal information as required:*
- (a) To carry out a specific state or federal law; or*
- (b) For the administration of a public program or an application for a federal or state grant.*
- Any action taken by a governmental agency pursuant to this subsection must not be construed as affecting the legality of the document.*
- 3. A governmental agency shall take necessary measures to ensure that notice of the provisions of this section is provided to persons with whom it conducts business. Such notice may include, without limitation, posting notice in a conspicuous place in each of its offices.*
- 4. A governmental agency may require a person who records, files or otherwise submits any document to the governmental agency to provide an affirmation that the document does not contain personal information about any person or, if the document contains any such personal information, identification of the specific law, public program or grant that requires the inclusion of the personal information. A governmental agency may refuse to record, file or otherwise accept a document which does not contain such an affirmation when required or any document which contains personal information about a person that is not required to be included in the document pursuant to a specific state or federal law, for the administration of a public program or for an application for a federal or state grant.*
- 5. Each governmental agency may ensure that any personal information contained in a document that has been recorded, filed or otherwise submitted to the governmental agency before January 1, 2007, which the governmental agency continues to hold is:*
- (a) Maintained in a confidential manner if the personal information is required to be included in the document pursuant to a specific state or federal law, for the administration of a public program or for an application for a federal or state grant; or*
- (b) Obliterated or otherwise removed from the document, by any method, including, without limitation, through the use of computer software, if the personal information is not required to be*

included in the document pursuant to a specific state or federal law, for the administration of a public program or for an application for a federal or state grant.

↪ *Any action taken by a governmental agency pursuant to this subsection must not be construed as affecting the legality of the document.*

6. *A person may request that a governmental agency obliterate or otherwise remove from any document submitted by the person to the governmental agency before January 1, 2007, any personal information about the person contained in the document that is not required to be included in the document pursuant to a specific state or federal law, for the administration of a public program or for an application for a federal or state grant or, if the personal information is so required to be included in the document, the person may request that the governmental agency maintain the personal information in a confidential manner. If any documents that have been recorded, filed or otherwise submitted to a governmental agency:*

(a) Are maintained in an electronic format that allows the governmental agency to retrieve components of personal information through the use of computer software, a request pursuant to this subsection must identify the components of personal information to be retrieved. The provisions of this paragraph do not require a governmental agency to purchase computer software to perform the service requested pursuant to this subsection.

(b) Are not maintained in an electronic format or not maintained in an electronic format in the manner described in paragraph (a), a request pursuant to this subsection must describe the document with sufficient specificity to enable the governmental agency to identify the document.

↪ *The governmental agency shall not charge any fee to perform the service requested pursuant to this subsection.*

7. *As used in this section:*

(a) "Governmental agency" means an officer, board, commission, department, division, bureau, district or any other unit of government of the State or a local government.

(b) "Personal information" has the meaning ascribed to it in [NRS 603A.040](#).

Chapter 239 of the NRS provides general principles for the definition and the handling of public records. In particular, subsection 239.010.3 states that:

A governmental entity that has legal custody or control of a public book or record shall not deny a request made pursuant to subsection 1 to inspect or copy or receive a copy of a public book or record on the basis that the requested public book or record contains information that is confidential if the governmental entity can redact, delete, conceal or separate the confidential information from the information included in the public book or record that is not otherwise confidential.

Chapter 445B of the NRS (Air Controls) specifically provides further directions on what is confidential information and how such information must be handle in the context of the Air Program of the NDEP. In particular section 445B.570 – *Confidentiality and use of information obtained by Department*¹; penalty – states that (footnotes added for clarity):

¹ Nevada Department of Conservation and Natural Resources (DCNR)

1. *Any information which the Department obtains in the course of the performance of its duties pursuant to the provisions of this chapter is public information unless otherwise designated as confidential information pursuant to the provisions of this section.*
2. *The emission of an air contaminant which has an ambient air quality standard or emission standard or has been designated as a hazardous air pollutant by regulation of the Commission cannot be certified as being confidential.*
3. *Any confidential information received by the Commission², the Director³ or any local control authority which is certified in writing to the recipient as confidential by the owner or operator disclosing the information and verified and approved in writing as confidential by the recipient must, unless the owner expressly agrees to its publication or availability to the public, be used only:
 - (a) *In the administration or formulation of air pollution controls;*
 - (b) *In compiling or publishing analyses or summaries relating to the condition of the outdoor atmosphere which do not identify any owner or operator or reveal any confidential information;*or
 - (c) *In complying with federal statutes, rules and regulations.**
4. *This section does not prohibit the use of confidential information in a prosecution for the violation of any statute, ordinance or regulation for the control of air pollution.*
5. *A person who discloses or knowingly uses confidential information in violation of this section is guilty of a misdemeanor, and is liable in tort for any damages which may result from such disclosure or use.*
6. *As used in this section, "confidential information" means information or records which:
 - (a) *Relate to dollar amounts of production or sales;*
 - (b) *Relate to processes or production unique to the owner or operator; or*
 - (c) *If disclosed, would tend to affect adversely the competitive position of the owner or operator.**

² Nevada State Environmental Commission

³ Director of the Department of Conservation and Natural Resources

ATTACHMENT B

**ELIGIBLE MITIGATION ACTION MANAGEMENT PLAN INCLUDING DETAILED
BUDGET AND IMPLEMENTATION AND EXPENDITURES TIMELINE**

ATTACHMENT B

PROJECT MANAGEMENT PLAN PROJECT SCHEDULE AND MILESTONES

Original Submission

Milestone	Date
NDEP begins solicitation for projects through the competitive Diesel Emission Mitigation Fund	CY 2019, Q2
Southwest Airlines submits application to NDEP	CY 2019, Q3
NDEP selects Southwest Airlines for funding	CY 2019, Q4
NDEP enters into Subgrant Agreement with Southwest Airlines	CY 2020, Q1
NDEP Submits and Trustee acknowledges receipt of project certification and funding direction	CY 2020, Q3
Project partner enters into Contracts, Purchase Orders, etc.	CY 2020, Q4
NDEP submits second "Advancement" payment request to Trustee	CY 2021, Q1
Southwest Airlines begins receiving new equipment	CY 2021, Q2
NDEP submits third "Advancement" payment request to Trustee	CY 2021, Q3
Southwest Airlines provides final invoice for equipment replacement to NDEP	CY 2021, Q3
NDEP completes review and certifies payment direction to Trustee (Reimbursement)	CY 2021, Q4
Trustee acknowledges receipt of direction for payment (Reimbursement)	CY 2021, Q4
NDEP reports project completion	CY 2022, Q1

August 22, 2022 Revision

Milestone	Date
NDEP begins solicitation for projects through the competitive Diesel Emission Mitigation Fund	CY 2019, Q2
Southwest Airlines submits application to NDEP	CY 2019, Q3
NDEP selects Southwest Airlines for funding	CY 2019, Q4
NDEP enters into Subgrant Agreement with Southwest Airlines	CY 2020, Q1
NDEP Submits and Trustee acknowledges receipt of project certification and funding direction	CY 2020, Q3
Project partner enters into Contracts, Purchase Orders, etc.	CY 2020, Q4
Southwest Airlines requests project extension	CY 2021
Project partner enters into new Contracts, Purchase Orders, etc.	CY 2022, Q2
Southwest Airlines begins receiving new equipment	CY 2023, Q1
Southwest Airlines provides final invoice for equipment replacement to NDEP	CY 2023, Q2
NDEP completes review and certifies payment direction to Trustee (Reimbursement)	CY 2023, Q3
Trustee acknowledges receipt of direction for payment (Reimbursement)	CY 2023, Q3
NDEP reports project completion	CY 2023, Q4

PROJECT BUDGET

Original Submission

Budget Category	Admin Expenses	Share of Replacement Budget Funded by the Trust	Cost Share (Paid by Project Partner)	Subtotal
Admin Expenditures¹				
Initial Payment Request	\$35,756.00			\$35,756.00
Second Payment Request	\$35,756.00			\$35,756.00
Third Payment Request	\$35,756.00			\$35,756.00
Final Payment Request	\$53,637.33			\$53,637.33
Admin Expenditure Subtotal	\$160,905.33			\$160,905.33
Equipment Expenditures				
1 LEKTRO AP8950SDB-AL-200 Electric Aircraft Tug		\$134,087.78	\$89,391.85	\$223,479.63
Subtotal for 8 Electric Aircraft Tugs		\$1,072,702.22	\$715,134.82	\$1,787,837.04
Subtotal for Equipment		\$1,072,702.22	\$715,134.82	\$1,787,837.04
Project Totals	\$160,905.33	\$1,072,702.22	\$715,134.82	\$1,948,742.37
Associated Percentages	15% of Total Trust Project Cost	60% of Replacement Cost	40% of Replacement Cost	

¹ The NDEP is planning to submit three “Advancement” payment requests to the Trustee to support the NDEP’s Administrative expenses associated with this project and one “Reimbursement” payment request to the Trustee that will include direction to provide funding to the NDEP for Administrative expenses and Southwest Airlines for the replacement of the airport ground support equipment. The first “Advancement” request is included with this Beneficiary Eligible Mitigation Action Certification and the two that will follow are expected to be submitted on a semiannual basis beginning in 2021 — that is, January 1, 2021 and July 1, 2021.

PROJECT BUDGET

August 22, 2022 Revision

Budget Category	Admin Expenses	Share of Replacement Budget Funded by the Trust	Cost Share (Paid by Project Partner)	Subtotal
Admin Expenditures				
Initial Payment Request	\$35,756.00			\$35,756.00
Final Payment Request	\$125,149.33			\$125,149.33
Admin Expenditure Subtotal	\$160,905.33			\$160,905.33
Equipment Expenditures				
1 TLD TMX-150-12-E DBP 100KN Electric Aircraft Tug		\$67,043.89	\$67,073.11	\$134,117.00
Subtotal for 14 Electric Aircraft Tugs		\$938,614.46	\$939,023.54	\$1,877,638.00
1 TLD TMX-150-12-E DBP 100KN Electric Aircraft Tug		\$67,043.88	\$67,073.11	\$134,117.00
Subtotal for 2 Electric Aircraft Tugs		\$134,087.76	\$134,146.22	\$268,234.00
Subtotal for Equipment		\$1,072,702.22	\$1,073,169.76	\$2,145,872.00
Project Totals	\$160,905.33	\$1,072,702.22	\$1,073,169.76	\$2,306,777.33
Associated Percentages	15% of Trust Project Cost	50% of Replacement Cost	50% of Replacement Cost	

PROJECTED TRUST ALLOCATIONS

Original Submission

ANNUAL PROJECTIONS	2020	2021
1. Anticipated annual project funding request to be paid through the Trust	\$35,756.00	\$1,197,851.55
2. Portion of anticipated project funding request to be paid through the Trust to cover Eligible Mitigation Action Administrative Expenditures	\$35,756.00	\$125,149.33
3. Portion of anticipated project funding request to be paid through the Trust to cover Eligible Mitigation Action Expenditures	-	\$1,072,702.22
4. Anticipated annual cost share	-	\$715,134.82
5. Anticipated total project funding by year (line 1 plus line 4)	\$35,756.00	\$1,912,986.37
CUMULATIVE PROJECTIONS		
6. Cumulative outstanding Trustee payments requested against cumulative approved Beneficiary allocation		\$7,479,211.88
7. Cumulative Trustee payments made to date against cumulative approved Beneficiary allocation		\$4,100,971.75
8. Beneficiary funding to be paid through the Trust for this project (sum of line 1)		\$1,233,607.55
9. Total funding approved for Beneficiary Eligible Mitigation Actions, inclusive of current Action (sum of lines 6, 7, and 8)		\$12,813,791.18
10. Beneficiary share of estimated funds remaining in Trust		\$20,773,052.73
11. Estimated Beneficiary funds remaining in Trust after project completion (line 10 minus lines 6 and 8)		\$12,060,233.30

PROJECTED TRUST ALLOCATIONS

August 22, 2022 Revision

ANNUAL PROJECTIONS	2020	2023
1. Anticipated annual project funding request to be paid through the Trust	\$35,756.00	\$1,197,851.55
2. Portion of anticipated project funding request to be paid through the Trust to cover Eligible Mitigation Action Administrative Expenditures	\$35,756.00	\$125,149.33
3. Portion of anticipated project funding request to be paid through the Trust to cover Eligible Mitigation Action Expenditures	-	\$1,072,702.22
4. Anticipated annual cost share	-	\$1,073,169.78
5. Anticipated total project funding by year (line 1 plus line 4)	\$35,756.00	\$2,271,021.33
CUMULATIVE PROJECTIONS		
6. Cumulative outstanding Trustee payments requested against cumulative approved Beneficiary allocation		\$9,629,980.46
7. Cumulative Trustee payments made to date against cumulative approved Beneficiary allocation		\$12,079,440.45
8. Beneficiary funding to be paid through the Trust for this project (sum of line 1)		\$1,233,607.55
9. Total funding approved for Beneficiary Eligible Mitigation Actions, inclusive of current Action (sum of lines 6, 7, and 8, minus line 8 from the original submission)		\$21,709,420.90
10. Beneficiary share of estimated funds remaining in Trust		\$13,924,030.00
11. Estimated Beneficiary funds remaining in Trust after project completion (line 10 minus lines 6 and 8)		\$4,294,049.55

ATTACHMENT C

**DETAILED PLAN FOR REPORTING ON ELIGIBLE MITIGATION ACTION
IMPLEMENTATION**

ATTACHMENT C

DETAILED PLAN FOR REPORTING ON ELIGIBLE MITIGATION ACTION IMPLEMENTATION

The Nevada Division of Environmental Protection (NDEP) will provide detailed reporting on this Volkswagen (VW) Environmental Mitigation Trust Fund for State Beneficiaries Eligible Mitigation Action project in two ways: 1, timely updates to NDEP's VW Environmental Mitigation Trust Fund webpage; and 2, Nevada's semiannual reporting obligation to Wilmington Trust (the "Trustee").

NDEP maintains a VW Environmental Mitigation Trust Fund specific webpage that has been designed to support public access and limit burden for the general public. The NDEP's VW specific webpage can currently be found at <https://ndep.nv.gov/air/vw-settlement>. Timely updates to the webpage will inform the general public on the project's status as well as when this Eligible Mitigation Action has been completed.

Subparagraph 5.3 of the Environmental Mitigation Trust Agreement for State Beneficiaries details Nevada's Reporting Obligations:

"For each Eligible Mitigation Action, no later than six months after receiving its first disbursement of Trust Assets, and thereafter no later than January 30 (for the preceding six-month period of July 1 to December 31) and July 30 (for the preceding six-month period of January 1 to June 30) of each year, each Beneficiary shall submit to the Trustee a semiannual report describing the progress implementing each Eligible Mitigation Action during the six-month period leading up to the reporting date (including a summary of all costs expended on the Eligible Mitigation Action through the reporting date). Such reports shall include a complete description of the status (including actual or projected termination date), development, implementation, and any modification of each approved Eligible Mitigation Action. Beneficiaries may group multiple Eligible Mitigation Actions and multiple sub-beneficiaries into a single report. These reports shall be signed by an official with the authority to submit the report for the Beneficiary and must contain an attestation that the information is true and correct and that the submission is made under penalty of perjury. To the extent a Beneficiary avails itself of the DERA Option described in Appendix D-2, that Beneficiary may submit its DERA Quarterly Programmatic Reports in satisfaction of its obligations under this Paragraph as to those Eligible Mitigation Actions funded through the DERA Option. The Trustee shall post each semiannual report on the State Trust's public-facing website upon receipt."

NDEP shall, in the next semiannual report following the Trustee's approval of this project, describe the progress implementing this Eligible Mitigation Action that will include a summary of all costs expended on the Eligible Mitigation Action through the reporting date. The report will also include a complete description of the status, development, implementation (including project schedule and milestone updates), and any modification to this Eligible Mitigation Action.

ATTACHMENT D

**DETAILED COST ESTIMATES FROM SELECTED OR POTENTIAL VENDORS FOR
EACH PROPOSED EXPENDITURE EXCEEDING \$25,000**

TLD Tuesday,
April 5, 2022

Offer ref : 2022030349-8

1 / 5

According to TLD America standard sales terms.



America
812 Bloomfield Ave.
Windsor, CT. 06095 USA
Phone: +1 (860)-602-3472
Fax: +1(860)-688-7895

SOUTHWEST AIRLINES (SWA)

Eric Kenney
P.O. Box 36611, HDQ-7PD
2702 Love Field Drive
Dallas TX 75235
USA

Tuesday, April 5, 2022

Offer ref : 2022030349-8

According to TLD America standard sales terms.



Eric,

In reply to your inquiry we are pleased to enclose our best offer for the following product(s)

TLD COMMERCIAL DESCRIPTION TO COMPLETE TMX-150-12-E, DBP 100KN (Qty:1)

Thank you for you for your interest in our products.

Kyle BRUNER

Commercial description to complete TMX-150-12-E, DBP 100kN

Version description

- 2 x ABM DG160LbR-6 3-phase AC motor
- Dana 360 dropbox, 2 Forward, 2 reverse gears
- Front and rear Dana-Spicer axles with wet discs brake
- Lead-acid battery assembly 1395Ah (Not included in the basic unit price)
- Curtis control system
- Front leaf springs
- 4 wheel drive, 4 wheel hydrostatic steering
- Dual braking circuit
- Parking brake activated by cable acting on front axle
- Standard lighting system: Turn signal, stop lamps, headlights, hazard lights, reverse lights and reverse buzzer
- Rear LED Work light
- Flashing beacon (amber) on cab roof
- Colorful Multi-Function-Display integrated in dashboard to show tractor status and warnings
- Common cab with metal doors (without roof window, doors painted in GREY RAL7024)
- Suspended driver seat plus 2x regular passenger seat
- Seat sensor for driver to prevent unexpected movement of the tractor if driver is not seated
- 1-level extended front & rear hitch with pin dia 70mm with self-locking and pin holder
- Rear hitch mirror
- Tire size 315/70R Continental
- TLD identity (Painted chassis by RAL 9016, zebra stickers at bottom of front and rear chassis)
- Each unit will be shipped together with one(1) hardcopy of printed Operation manual. Full manual can be downloaded from TLD WEB



Uncontractual picture

- TLD WUX 56) English language and imperial unit in HMI display
- Passenger style seat in lieu of driver seat
- TLD WUX 14) Complete set of printed TLD manuals (including C
- TLD WUX 33) Cab door retainers on both left and right side
- TLD WUX 02) Tractor painted in other color than TLD identity
- TLD WUX 53) TMX-150-12-E Material surcharge
- TLD WUX 31) Dead man pedal in lieu of driver seat sensor
- TLD WUX 28) Jack plugs for intercom system (Qty 3)
- TLD WUX 18) Front hitch and rear view camera with color monitor
- TLD WUX 09) Centralized automatic greasing system
- TLD WUX 05) 12VDC power supply socket (for radio)
- TLD WUX 001-01) Central watering system (battery accessory, Charger BMID Installation - SWA to Specify Charger Type
- Non Split Rim Wheels
- TLD WUX 07) Cabin fan (Qty 1)

Basic Options

Unit Price, EXW: WUXI	99,529 USD
Transportation: Wuxi to USA	9,235 USD
China Import Tariff	22,132 USD
Quantity	1
SWA Discount	
Total Price, EXW: TBD	119,896 USD
+ Battery	14,221 USD
TOTAL	\$134,117 USD

1) GENERALITY

This offer is subject to (i) the “TLD General Terms and Conditions of Sales” (see Appendix 1) (ii) the following specific terms. In the event of any discrepancies between the General Terms and Conditions and the present offer, the specific terms of this offer shall prevail. Any terms and conditions of the Buyer shall apply only in case of TLD’s express written consent. Any reference to “TLD” herein shall mean the entity of the TLD Group signing this Offer, as indicated below.

1- PAYMENT

Net 30 Days

2- VALIDITY

This offer remains valid for 30 days as of the date indicated above.

3- DELIVERY

At the date of this offer, TLD’s best delivery date is

Commercial description to complete TMX-150-12-E, DBP 100kN :
TBD

This delivery date shall be considered confirmed after Buyer sends a formal purchase order and down payment is received by TLD. Depending on factory work-load at the date of the Buyer’s purchase order, TLD may adjust the delivery schedule to meet mutual convenience.

4- WARRANTY

The equipment delivered by TLD is guaranteed against any material and construction defects, in accordance with TLD general warranty conditions (available on TLD website at <https://www.tld-group.com/wp-content/uploads/tld-media/tld-general-warranty-conditions.pdf>), for: (i) a period of 24 months after being placed in service; or (ii) after 2000 operating hours if the main engine of the unit is under 50KW; or (iii) 3000 operating hours if main engine of the unit is above 50KW, whichever first occurs. The warranty claims are only considered after full payment of the equipment by the Buyer to TLD.

5- PENALTIES ON LATE DELIVERIES

TLD shall not be subject to late delivery penalties or any kind of liability for any delays. Without prejudice to the foregoing, TLD shall make all necessary efforts to deliver the goods on time.

6- PENALTY FOR CONTRACT CANCELLATION

Any order/contract cancellation requested by the Buyer at any time will entitle TLD to invoice the full price of the equipment ordered and/or to execute at its own discretion, any of the provisions of Article 8 of TLD General Terms and Conditions of Sales.

7) RESERVATION OF OWNERSHIP - TRANSFER OF RISKS

Under the provisions of Article 9 of TLD General Terms and Conditions of Sales, TLD shall retain title to the equipment until full payment of its price. Payment shall not be considered effective until the entire amounts are received by TLD. Notwithstanding the foregoing, all risks, liabilities and costs regarding the equipment are transferred to the Buyer upon its delivery.

8- TRANSPORT RESPONSIBILITIES

The equipment is sold Ex Works (EXW) TLD's Premises. TLD shall be responsible for packaging and marking, as well as making the equipment available for pick-up. The Buyer shall be responsible for any customs formalities, including paying any export fees and taxes and obtaining any export licenses.

The Buyer shall choose its means of transport (including selecting its own transportation or freight forwarder company) and bear all the related costs (including insurance costs), liability and risks. TLD cannot be held liable for missing or damaged items within the transportation. It is the Buyer's responsibility to check equipment and potential shipping damage at arrival on site, to express any reservations on the delivery slip, and, if appropriate, to take any recourse against the carriers and to inform TLD within two (2) business days. Any import duties and formalities shall also be the Buyer's responsibilities.

TLD shall not be held liable for any delays occurring in shipments and transport. Only the party responsible for transport can be held liable for any claims related to damages resulting from such delays.

If purchased equipment is delivered by TLD to the Buyer or a carrier on behalf of the Buyer (or picked up from TLD by the Buyer or a carrier on behalf of the Buyer) at TLD's plants and warehouses, the personnel in TLD factories shall not be deemed qualified to assess if the equipment used for transportation is adequate or not. Loading shall be carried out under the authority and responsibility of the Buyer, its employees or agents, and it will not, under any circumstances, result in any liability to TLD. Under no circumstances may the Buyer hold TLD or its personnel liable for any reason whatsoever, resulting directly or indirectly from any handling of the equipment that is the subject of this sales offer.

It is expressly agreed that TLD will not be required to pay any compensation to the Buyer for any injury or death, or damages to property (of Buyer or third parties), unless caused by TLD's gross negligence, duly evidenced. Gross negligence means an act or omission by TLD demonstrating an obvious lack of precaution by TLD with regard to the seriousness of the consequences that any diligent professional would have normally carried out. Notwithstanding the foregoing, unless otherwise established by the applicable law, TLD shall not be liable for any indirect liability (including, but not limited to loss of real or projected revenue/earnings and loss of business opportunities)

9- TECHNICAL LITERATURE

With each piece of equipment one printed manual (Chapter 0 and 1 only) is provided. On request, you can access the manuals for your TLD equipment in TLD Extranet and obtain the electronic version, which contains the following chapters:

- Chapter 0: Introduction
- Chapter 1: General Information & Operating Instructions
- Chapter 2: Maintenance
- Chapter 3: Overhaul / Major repair
- Chapter 4: Illustrated Parts List
- Chapter 5: Manufacturers' Appendices Original Components Manufacturers technical literature

The Buyer commits to study the provided documentation with care and to ensure that all employees are aware of its existence and understand its content. The correct use of the equipment sold is the responsibility of the Buyer.

10- TECHNICAL RECEPTION & TRAINING

Pre-delivery Inspection in TLD's factory: Included in TLD prices. (This does not include transportation and accommodation costs – these are paid by the Buyer.)

Training: Any training of personnel in the operation and maintenance of TLD's equipment can be undertaken at TLD's premises or on the operations site.

We remain at your entire disposal for any additional information you may require.

Sincerely Yours.

Kyle Bruner
TLD America

TLD Tuesday,
April 5, 2022

Offer ref : 2022030349-8

5 / 5

According to TLD America standard sales terms.

11) BUYER ACCEPTANCE

This offer is hereby accepted by the Buyer:

BUYER'S NAME:

BUYER'S REPRESENTATIVE NAME:

TITLE:

DATE, PLACE:

SIGNATURE:

12- BANKING REFERENCE

Wire Transfer Instructions: TLD America Corporation
812 Bloomfield Ave.
Windsor, CT 06095

Bank: HSBC Bank USA N.A.
452 5th Avenue
New York, NY 10018

In Favor of: TLD America

ABA #: 021001088

Account #: 000271900

Swiftcode: MRMDUS33

Please include a memo line in the body of the wire transfer as to what invoice numbers you are paying for.

Please email me when you are transferring funds, and include a note line stating the invoices you are paying for. This is a must.

Thank you,
Kevin Camara
Controller
receivables@tld-america.com

Thank you for this opportunity to provide you with this quote. Please do not hesitate to contact me if I can be of assistance for any additional information you may require.

Sincerely Yours,

Kyle BRUNER
Area Sales Manager
Mobile phone: +1 860-549-2857
kyle.bruner@tld-america.com

TMX-150-e

ELECTRICAL AIRCRAFT TOWBAR TRACTOR



DESCRIPTION

The TMX-150-e is an electric aircraft tow bar tractor, with a maximum draw bar pull up to 100 kN (~22,480 lbf), designed to perform pushback and towing operations. It can cover all current narrow body aircraft up to B757 and new designed aircraft like A321_{neo} or COMAC C919. Its ergonomic design provides maximum driver comfort, safety and excellent visibility. Like all TLD tractors, the TMX-150-e is very simple in design, easy to use and easy to maintain.

DRIVELINE CAPABILITY

Model	GVW	Max DBP
TMX-150-9	9,150 kg (20,172 lb)	68 kN (15,287 lbf)
TMX-150-12	12,250 kg (27,006 lb)	100 kN (22,480 lbf)

Friction coefficient on dry concrete

STANDARD FEATURES

- **Motor** : ABM - 27KW x 2
- **Inverter** : Curtis – 1238
- **Transmission** : DANA 360 Dropbox transmission, 2 forward and 2 reverse , 4 wheels drive
- **Maximum speed** : (without load)
Maximum forward speed : 25 kph (~15,53 mph)
Maximum reverse speed : 25 kph (~15,53 mph)
- **Front axle** : DANA SPICER steering and driving axle with leaf spring suspension
- **Rear axle** : DANA SPICER steering and driving axle, rigid mounted
- **Service Brake** : Dual circuit on 4 wheels, immersed wet discs hydraulically powered brake system
- **Parking Brake** : Immersed wet disc brake on 2 front wheels, mechanically actuated
- **Steering** : Hydraulically-powered, 4WS
- **Tow hitch**: Front and rear extended hitch with pin Ø70 mm (2.75"), 1 level, manually controlled safety lock
- **Tires** : 315/70-15
- **Hydraulic tank capacity** : 45 liters (11 US GAL)
- **Paint** : White – RAL 9016

HYDRAULIC SYSTEM

- 1 hydraulic pump station for power steering and braking

CAB STANDARD EQUIPMENT

- 1 luxury suspended seat for driver and 2 normal seats for passengers
- A big colorful display integrated hour meter, BDI, motor rpm, driving speed, parking brake light, warning lights, lights indicator, gear status, fault indicator, etc.
- Double front windscreen wipers with washer
- Cab heater and ventilation
- Mirror on front hitch
- Front working light LED

Power package

Standard feature

- **Battery**: 80V/1395Ah Hoppecke lead-acid battery, with centralized watering system, trak® air system
- **Charger**: Tropicalized charger (200A), outdoor (sheltered) use. Charging time is 8 hours

Option

- CAMY 80V, NCM battery (SAMSUNG cell, packed with Fire Suppression System)
- CAMY 80V, LFP battery (Hengdong cell, packed with Fire Suppression System)

Specifications may be altered as a constant effort to improve performance.
Tolerance of data: +/- 5 %, some views may show optional equipment.

TMX-150-e

ELECTRICAL EQUIPMENT

Electrical system equipped with the following items:

- 1395 Ah Lead-acid batteries
- DC-DC converter: 900w, 24VDC/37A output
- LED lights : Front and rear headlights, working lights on front and rear hitches, stop lights, turn signal, hazard lights
- Flashing beacon
- Back-up alarm and reverse light

DIMENSIONS

- Inside turning radius.....1 650 mm (65")
- Outside turning radius.....4 690 mm (185")

OPTIONS AVAILABLE

- Special hitches (2 & 3 levels, regional aircraft, hydraulic hitches, etc.)
- Centralized greasing
- Customized beacon
- Fire extinguisher (8kg ABC powder)
- Air conditioning
- De-icing windscreens
- Jack plugs
- Cab heater
- Front and rear view cameras

* Further options on request

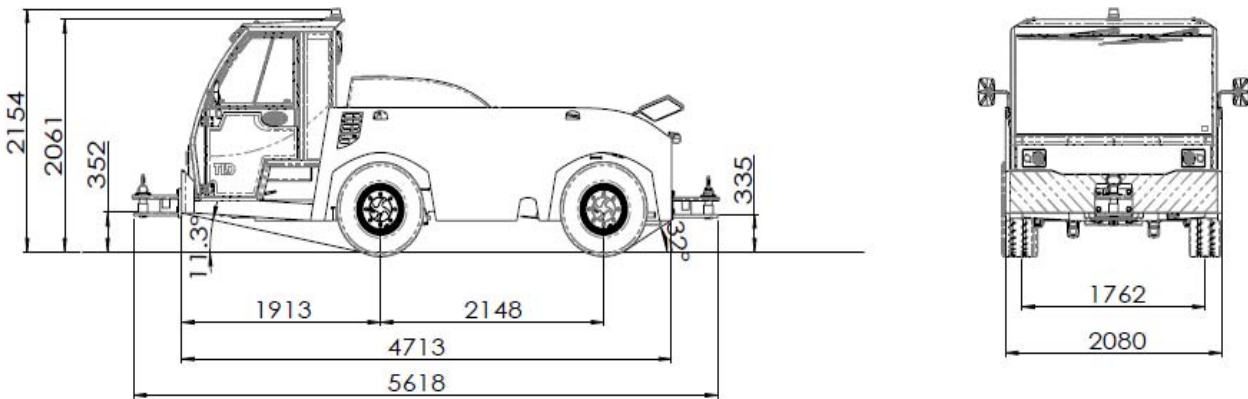

Revised on 21st Mar, 2018 by SL

TLD Sales and Service regional headquarters

- **TLD ASIA** South East Asia & South Korea
 Hong Kong Tel : + 852 2692-2181
- **TLD CHINA** China
 Shanghai, PRC Tel : + 86 21 5815 3322
- **TLD EUROPE** Europe, Russia, Central Asia, & West Africa
 Sorigny, France Tel : + 33 2 47 45 77 77
- **TLD MEA** Middle East, East Africa & India
 Dubai, UAE Tel : + 971 47 030 410
- **TLD LAAJ** Latin America, Oceania & Japan
 Miami, FL, USA Tel : + 1 305 716 1130
- **TLD AMERICA** USA & Canada
 Windsor, CT, USA Tel : + 1 860 602 3400

Contact us on our Web site: www.tld-group.com



ALTUS

The World's only Cloud-Connected Charger for Demanding eGSE Applications

Take Control of Your eGSE Fleet

Minit Charger, a recognized leader in fast charging technology, just raised the bar again. Altus, our robust charging solution for eGSE is now connected to our cloud portal AssetPro. Altus empowers airport personnel to better manage their fleet with unprecedented visibility and insight on charger and GSE performance.

- + Dual Port Charger
- + Multiple Power Output Options
- + High-Frequency IGBT Technology
- + Outdoor Rated Enclosure
- + Monitor/Configure Charger from Anywhere
- + Charger Can Share Jet Bridge Power with Optional Bridge Power Manager
- + Wireless Battery Module
- + Break-Away Charge Cables
- + High-Visibility Status LEDs
- + Four-line Status Display

Advanced Battery Management

In addition to our patented technology, we have added advanced battery management to improve battery performance and extend life. Altus can be purchased with an optional wireless battery management system which sends up-to-the-minute data on battery voltage, amp hours delivered and returned, temperature and electrolyte level to the AssetPro server.



AssetPro Cloud-Based Asset Management

AssetPro collects data from all chargers, battery management devices, and even vehicle monitoring devices. The data is organized in heads-up dashboards, detailed status pages, and customizable reports for intelligent management of the entire fleet.

AssetPro can also send emails to management when equipment needs immediate attention.

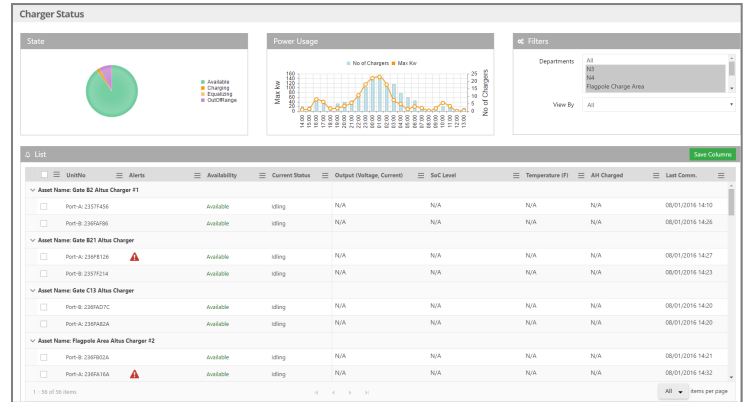

Altus Charger Specifications

Input Power	Output Power/Port	General
Altus 22kW Dual Port Charger		
380/400/480 VAC, 3 Phase, 50/60 Hz	Voltage: 24V-96V nominal	Dimension: 68" H x 32" W x 24" D
Rated Current @ 480VAC: 32 A	Max Current: 130 A	Weight: (Approx) 350 Lbs. / 160kg
Rated Current @ 400VAC: 40 A		
Rated Current @ 380VAC: 42 A		
Efficiency: up to 93%		
Altus 30kW Dual Port Charger		
480 VAC, 3 Phase, 50/60 Hz	Voltage: 24V-96V nominal	Dimension: 68" H x 32" W x 24" D
Rated Current @ 480VAC: 42 A	Max Current: 320 A	Weight: (Approx) 450 Lbs. / 205kg
Altus 40kW Dual Port Charger		
480 VAC, 3 Phase, 50/60 Hz	Voltage: 24V-96V nominal	Dimension: 68" H x 32" W x 24" D
Rated Current @ 480VAC: 54 A	Max Current: 320 A	Weight: (Approx) 450 Lbs. / 205kg

Enclosure: NEMA 3R / IP23 Outdoor rated

Warranty: 2 Years Parts, 1 Year Labor

Temperature: -13° to 104° F (-25° to 40° C)

Certifications: UL1564 for Outdoor Use

As part of our continuous improvement policy, product specifications may change without notice.

MINIT CHARGER
www.minitcharger.com

908-789-8700