

If applicable, describe how the mitigation action will mitigate the impacts of NOx emissions on communities that have historically borne a disproportionate share of the adverse impacts of such emissions (5.2.10).

n/a

ATTACHMENTS
(CHECK BOX IF ATTACHED)

- Attachment A** **Funding Request and Direction.**
- Attachment B** **Eligible Mitigation Action Management Plan Including Detailed Budget and Implementation and Expenditures Timeline (5.2.4).**
- Attachment C** **Detailed Plan for Reporting on Eligible Mitigation Action Implementation (5.2.11).**
- Attachment D** **Detailed cost estimates from selected or potential vendors for each proposed expenditure exceeding \$25,000 (5.2.6). [Attach only if project involves vendor expenditures exceeding \$25,000.]**
- Attachment E** **DERA Option (5.2.12). [Attach only if using DERA option.]**
- Attachment F** **Attachment specifying amount of requested funding to be debited against each beneficiary's allocation (5.2.13). [Attach only if this is a joint application involving multiple beneficiaries.]**

CERTIFICATIONS

By submitting this application, the Lead Agency makes the following certifications:

- 1. This application is submitted on behalf of Beneficiary Nevada, and the person executing this certification has authority to make this certification on behalf of the Lead Agency and Beneficiary, pursuant to the Certification for Beneficiary Status filed with the Court.**
- 2. Beneficiary requests and directs that the Trustee make the payments described in this application and Attachment A to this Form.**
- 3. This application contains all information and certifications required by Paragraph 5.2 of the Trust Agreement, and the Trustee may rely on this application, Attachment A, and related certifications in making disbursements of trust funds for the aforementioned Project ID.**
- 4. Any vendors were or will be selected in accordance with a jurisdiction's public contracting law as applicable. (5.2.5)**
- 5. Beneficiary will maintain and make publicly available all documentation submitted in**

support of this funding request and all records supporting all expenditures of eligible mitigation action funds subject to applicable laws governing the publication of confidential business information and personally identifiable information. (5.2.7.2)

DATED: 2/20/2020

Danilo Dragoni, PhD
[NAME]

[SIGNATURE]

Chief, Bureau of Air Quality Planning
[TITLE]

Nevada Division of Environmental Protection
[LEAD AGENCY]

for

Nevada
[BENEFICIARY]

**DETAILED DESCRIPTION OF MITIGATION ACTION ITEM INCLUDING
COMMUNITY AND AIR QUALITY BENEFITS (5.2.2)**

This Eligible Mitigation Action Category 9 project will install publicly available light duty electric vehicle charging infrastructure at a non-Government Owned Property in Silver Springs, Nevada. Specifically, the charging infrastructure will be installed at the Silver Springs Nugget Casino at 1280 Lincoln Hwy, Silver Springs, NV 89429. Two Direct Current Fast Chargers (the charger will have two cords, one SAE Combo and one CHAdeMO, but only one can be in use at a time) and one two-port Level 2 charger will be installed because of this project.

This project supports the development of the Nevada Electric Highway. Once completed, the Nevada Electric Highway will provide a network of electric vehicle charging stations across the state in order to make it easier for Nevadans and our guests alike to appreciate all the state has to offer. By investing in the charging infrastructure identified in the Nevada Electric Highway and this Eligible Mitigation Action specifically, Environmental Mitigation Trust Funds will help to increase the availability of charging stations for electric vehicles and thus increase electric vehicle usage in Nevada’s metropolitan areas, as well as significantly contribute to an increase in the number of electric vehicles driven across not only Nevada, but the entire western region.

Through this Nevada Electric Highway project, the Nevada Division of Environmental Protection (NDEP) will advance funding to the Nevada Governor’s Office of Energy (GOE) who will directly oversee the completion of the project. The GOE’s project partner will then be reimbursed on actual expenditures incurred over the course of the charging infrastructure’s installation. The GOE will provide progress reports to the NDEP detailing the work done to complete the project and once completed, any unspent Trust funds will be returned to Wilmington Trust.

The expected lifetime emissions reductions (listed in the table below) are based on the Federal Highway Administration’s Congestion Mitigation and Air Quality Improvement Program’s Cost Effectiveness Tables. An important assumption associated with this project, but not considered in the below estimates, is that as the number of electric vehicles increases so too will the amount of emissions reduced due to the installation of this charging infrastructure.

Pollutant	Emissions Reductions (tons)
NOx	0.081
PM _{2.5}	0.007
VOC	0.033
CO	1.326
PM ₁₀	0.017

ATTACHMENT FOR 5.2.7.2

Describe how the Beneficiary will make documentation publicly available

Subparagraph 5.2.7.2 of the Environmental Mitigation Trust Agreement for State Beneficiaries requires that Beneficiaries include in their funding requests:

A commitment by the Beneficiary to maintain and make publicly available all documentation submitted in support of the funding request and all records supporting all expenditures of Eligible Mitigation Action funds, subject to applicable laws governing the publication of confidential business information and personally identifiable information, together with an explanation of the procedures by which the Beneficiary shall make such documentation publicly available;

The Nevada Division of Environmental Protection (NDEP), the Lead Agency for the State of Nevada, is committed to maintaining and making publicly available all documentation submitted support of the funding requests and all records supporting all expenditures of Eligible Mitigation Action funds, subject to applicable laws governing the publication of confidential business information and personally identifiable information.

The public will be able to view these records on the NDEP's website (<https://ndep.nv.gov>). The NDEP will maintain these records on a Volkswagen (VW) Environmental Mitigation Trust Fund specific webpage that will be designed to support public access and limit burden for the general public. The NDEP's VW specific webpage can currently be found at <https://ndep.nv.gov/air/vw-settlement>.

The NDEP has created an electronic listserv, open to the public, used to communicate news, events, and information related the Environmental Mitigation Trust Fund (Mitigation Fund). The listserv, NevadaVWFund, is advertised through the NDEP website and at public events related to the Mitigation Fund.

Chapters 603A and 239B of the Nevada Revised Statutes (NRS) provide definitions and requirements for handling *personal information*.

NRS Section 603A.040 defines 'Personal Information' as:

1. *"Personal information" means a natural person's first name or first initial and last name in combination with any one or more of the following data elements, when the name and data elements are not encrypted:*
 - (a) *Social security number.*
 - (b) *Driver's license number, driver authorization card number or identification card number.*
 - (c) *Account number, credit card number or debit card number, in combination with any required security code, access code or password that would permit access to the person's financial account.*
 - (d) *A medical identification number or a health insurance identification number.*

- (e) A user name, unique identifier or electronic mail address in combination with a password, access code or security question and answer that would permit access to an online account.*
- 2. The term does not include the last four digits of a social security number, the last four digits of a driver's license number, the last four digits of a driver authorization card number or the last four digits of an identification card number or publicly available information that is lawfully made available to the general public from federal, state or local governmental records.*

NRS Section 239B.030 – *Recorded, filed or otherwise submitted documents* - states that:

- 1. Except as otherwise provided in subsections 2 and 6, a person shall not include and a governmental agency shall not require a person to include any personal information about a person on any document that is recorded, filed or otherwise submitted to the governmental agency on or after January 1, 2007.*
- 2. If personal information about a person is required to be included in a document that is recorded, filed or otherwise submitted to a governmental agency on or after January 1, 2007, pursuant to a specific state or federal law, for the administration of a public program or for an application for a federal or state grant, a governmental agency shall ensure that the personal information is maintained in a confidential manner and may only disclose the personal information as required:*
- (a) To carry out a specific state or federal law; or*
- (b) For the administration of a public program or an application for a federal or state grant.*
- ↪ Any action taken by a governmental agency pursuant to this subsection must not be construed as affecting the legality of the document.*
- 3. A governmental agency shall take necessary measures to ensure that notice of the provisions of this section is provided to persons with whom it conducts business. Such notice may include, without limitation, posting notice in a conspicuous place in each of its offices.*
- 4. A governmental agency may require a person who records, files or otherwise submits any document to the governmental agency to provide an affirmation that the document does not contain personal information about any person or, if the document contains any such personal information, identification of the specific law, public program or grant that requires the inclusion of the personal information. A governmental agency may refuse to record, file or otherwise accept a document which does not contain such an affirmation when required or any document which contains personal information about a person that is not required to be included in the document pursuant to a specific state or federal law, for the administration of a public program or for an application for a federal or state grant.*
- 5. Each governmental agency may ensure that any personal information contained in a document that has been recorded, filed or otherwise submitted to the governmental agency before January 1, 2007, which the governmental agency continues to hold is:*
- (a) Maintained in a confidential manner if the personal information is required to be included in the document pursuant to a specific state or federal law, for the administration of a public program or for an application for a federal or state grant; or*
- (b) Obliterated or otherwise removed from the document, by any method, including, without limitation, through the use of computer software, if the personal information is not required to be*

included in the document pursuant to a specific state or federal law, for the administration of a public program or for an application for a federal or state grant.

➤ *Any action taken by a governmental agency pursuant to this subsection must not be construed as affecting the legality of the document.*

6. *A person may request that a governmental agency obliterate or otherwise remove from any document submitted by the person to the governmental agency before January 1, 2007, any personal information about the person contained in the document that is not required to be included in the document pursuant to a specific state or federal law, for the administration of a public program or for an application for a federal or state grant or, if the personal information is so required to be included in the document, the person may request that the governmental agency maintain the personal information in a confidential manner. If any documents that have been recorded, filed or otherwise submitted to a governmental agency:*

(a) Are maintained in an electronic format that allows the governmental agency to retrieve components of personal information through the use of computer software, a request pursuant to this subsection must identify the components of personal information to be retrieved. The provisions of this paragraph do not require a governmental agency to purchase computer software to perform the service requested pursuant to this subsection.

(b) Are not maintained in an electronic format or not maintained in an electronic format in the manner described in paragraph (a), a request pursuant to this subsection must describe the document with sufficient specificity to enable the governmental agency to identify the document.

➤ *The governmental agency shall not charge any fee to perform the service requested pursuant to this subsection.*

7. *As used in this section:*

(a) "Governmental agency" means an officer, board, commission, department, division, bureau, district or any other unit of government of the State or a local government.

(b) "Personal information" has the meaning ascribed to it in [NRS 603A.040](#).

Chapter 239 of the NRS provides general principles for the definition and the handling of public records. In particular, subsection 239.010.3 states that:

A governmental entity that has legal custody or control of a public book or record shall not deny a request made pursuant to subsection 1 to inspect or copy or receive a copy of a public book or record on the basis that the requested public book or record contains information that is confidential if the governmental entity can redact, delete, conceal or separate the confidential information from the information included in the public book or record that is not otherwise confidential.

Chapter 445B of the NRS (Air Controls) specifically provides further directions on what is confidential information and how such information must be handle in the context of the Air Program of the NDEP. In particular section 445B.570 – *Confidentiality and use of information obtained by Department*¹; penalty – states that (footnotes added for clarity):

¹ Nevada Department of Conservation and Natural Resources (DCNR)

1. *Any information which the Department obtains in the course of the performance of its duties pursuant to the provisions of this chapter is public information unless otherwise designated as confidential information pursuant to the provisions of this section.*
2. *The emission of an air contaminant which has an ambient air quality standard or emission standard or has been designated as a hazardous air pollutant by regulation of the Commission cannot be certified as being confidential.*
3. *Any confidential information received by the Commission², the Director³ or any local control authority which is certified in writing to the recipient as confidential by the owner or operator disclosing the information and verified and approved in writing as confidential by the recipient must, unless the owner expressly agrees to its publication or availability to the public, be used only:
 - (a) *In the administration or formulation of air pollution controls;*
 - (b) *In compiling or publishing analyses or summaries relating to the condition of the outdoor atmosphere which do not identify any owner or operator or reveal any confidential information;*or
 - (c) *In complying with federal statutes, rules and regulations.**
4. *This section does not prohibit the use of confidential information in a prosecution for the violation of any statute, ordinance or regulation for the control of air pollution.*
5. *A person who discloses or knowingly uses confidential information in violation of this section is guilty of a misdemeanor, and is liable in tort for any damages which may result from such disclosure or use.*
6. *As used in this section, "confidential information" means information or records which:
 - (a) *Relate to dollar amounts of production or sales;*
 - (b) *Relate to processes or production unique to the owner or operator; or*
 - (c) *If disclosed, would tend to affect adversely the competitive position of the owner or operator.**

² Nevada State Environmental Commission

³ Director of the Department of Conservation and Natural Resources

ATTACHMENT A

FUNDING REQUEST AND DIRECTION

ATTACHMENT B

**ELIGIBLE MITIGATION ACTION MANAGEMENT PLAN INCLUDING DETAILED
BUDGET AND IMPLEMENTATION AND EXPENDITURES TIMELINE**

ATTACHMENT B

PROJECT MANAGEMENT PLAN PROJECT SCHEDULE AND MILESTONES

Milestone	Date
The Nevada Governor’s Office of Energy received the application from NV Energy for the installation of eligible electric vehicle charging infrastructure	CY 2019, Q3
GOE enters into Agreement with NV Energy	CY 2019, Q3
GOE submits application to NDEP	CY 2019, Q4
NDEP enters into Subgrant Agreement with GOE	CY 2020, Q1
NDEP Submits and Trustee acknowledges receipt of project certification and funding direction	CY 2020, Q1
NV Energy completes installation of electric vehicle charging infrastructure	CY 2020, Q4
GOE reports project completion to NDEP	CY 2021, Q1
NDEP reports project completion—any unspent VW State Trust funds will be returned to the Trustee	CY 2021, Q1

PROJECTED TRUST ALLOCATIONS

ANNUAL PROJECTIONS	2020
1. Anticipated annual project funding request to be paid through the Trust	\$ 66,743.60
2. Portion of anticipated project funding request to be paid through the Trust to cover Eligible Mitigation Action Administrative Expenditures	\$ 6,067.60
3. Portion of anticipated project funding request to be paid through the Trust to cover Eligible Mitigation Action Expenditures	\$ 60,676.00
4. Anticipated annual cost share	\$ 182,026.00
5. Anticipated total project funding by year (line 1 plus line 4)	\$ 248,769.60
CUMULATIVE PROJECTIONS	
6. Cumulative outstanding Trustee payments requested against cumulative approved Beneficiary allocation	\$ 6,715,945.29
7. Cumulative Trustee payments made to date against cumulative approved Beneficiary allocation	\$ 3,172,514.14
8. Beneficiary funding to be paid through the Trust for this project (sum of line 1)	\$ 66,743.60
9. Total funding approved for Beneficiary Eligible Mitigation Actions, inclusive of current Action (sum of lines 6, 7, and 8)	\$ 9,955,203.03
10. Beneficiary share of estimated funds remaining in Trust	\$ 22,379,377.47
11. Estimated Beneficiary funds remaining in Trust after project completion (line 10 minus lines 6 and 8)	\$ 15,596,688.58

**GOE NEH Funding Opportunity April 2018
Attachment 2: Subgrant Workplan Template**

Name of Applicant:	NV Energy	Name of Project:	NEH Site# 24 – Silver Spring Nugget Casino
--------------------	-----------	------------------	--

Task/Milestone	Start Date	Activity	Deliverable	Detailed Description	Completion Date
Task/Milestone 1	Upon sign-age of the Grant Agreement	<i>Site Selection</i>	<i>Report to GOE will include a map of the location with the on-site power availability (e.g., 3-phase) Expect approximately 10% of the budget will be allocated for this Task/Milestone</i>	<i>NV Energy will provide GOE with a site map and power availability memo per Rule 9 requirements.</i>	TBD
Task/Milestone 2	TBD	<i>Design</i>	<i>Report to GOE will include the drawings, specifications, etc. Expect approximately 15% of the budget will be allocated for this Task/Milestone</i>	<i>NV Energy will review and ensure design, drawings and specifications follow standard industry practice. These drawings will be provided for GOE's review and approval.</i>	TBD
Task/Milestone 3	TBD	<i>Equipment purchase</i>	<i>Report to GOE will include the equipment specifications. Expect approximately 35% of the budget will be allocated for this Task/Milestone</i>	<i>NV Energy will review and ensure the equipment specs out properly for the design of the charging station and uses industry standard purchasing processes that ensure fairness. These specs will be provided for GOE review and approval.</i>	TBD
Task/Milestone 4	TBD	<i>Construction/Installation</i>	<i>Report to GOE will include construction start/end dates, labor used (e.g., in-house, subcontract) Expect approximately 35% of the budget will be allocated for this Task/Milestone</i>	<i>NV Energy will review and ensure Contractor performs and/or contracts out the construction and installation of the charging station in a fair and reasonable manner with all phases of this milestone meeting standard construction and engineering specifications. Furthermore, NV Energy will provide the construction reports for GOE's review and approval.</i>	TBD
Task/Milestone 5	TBD	<i>Final Closeout</i>	<i>Final report to GOE will include wrap-up of the project, photos of the completed installation, final</i>	<i>NV Energy will review and ensure the final report, to be submitted to the Nevada GOE, is complete and documents all phases of the</i>	12/31/2020

**GOE NEH Funding Opportunity April 2018
Attachment 2: Subgrant Workplan Template**

Task/ Milestone	Start Date	Activity	Deliverable	Detailed Description	Completion Date
			<i>invoices for equipment purchases and post construction design updates (as-built drawings, specs, costs). Expect approximately 5% of the budget will be allocated for this Task/Milestone</i>	<i>project as outlined in these task, milestones and budgets.</i>	

Notes: Complete the table above. The items pre-populated are suggested items. Percentages noted are estimates and are adjustable, based on the individual subgrantee. Tie each Task/milestone to the budget on the budget template provided. Provide a more detailed description of the work that will take place in order to complete each Task/Milestone, including information on how the Deliverable will be produced and to what specifications.

**GOE NEH Funding Opportunity April 2018
Attachment 3: Subgrant Budget Template**

PROJECT BUDGET

E. CONTRACTUAL: Contractual will cover the costs of subcontractors or subrecipients other than the Prime Applicant.

Name of subcontractor or subrecipient	Justification	Task/Mile stone 1	Task/Mile stone 2	Task/Milestone 3	Task/Miles tone 4	Task/Mile stone 5	Total Amount
Verdek LLC.			10799.5		57316.76	24067.56	\$ 92,184
							\$ -
							\$ -
							\$ -
							\$ -
							Contractual Subtotal: \$ 92,184

F. OTHER: Other costs are items required for the project which do not fit clearly into the other categories. Examples are conference fees, subscription costs, printing costs, etc.

Description	Justification	Task/Mile stone 1	Task/Mile stone 2	Task/Milestone 3	Task/Miles tone 4	Task/Mile stone 5	Total Amount
Line extention.		5000			25200		\$ 30,200
							\$ -
							\$ -
							\$ -
							\$ -
							Other Subtotal: \$ 30,200

Total Project Cost: \$ 242,702

Project Budget Summary	
	Total Request from GOE: 60,675.60
	Portion Covered by NVE: 182,026.79
	Check -> 242,702

GOE Site Number
 Highway:
 Site location:
 Site Physical Address:

24
 U.S. Route 50 / Lincoln Highway
 Silver Springs Nugget Casino
 1280 Lincoln Highway, Silver Springs, NV 89429

Other*		UOM	\$/UOM*	Value/QTY	Total/UOM	Notes
		EA			\$ -	
Construction Fencng	*	LOT	\$ 3,500.00	1	\$ 3,500.00	
Storage Bin	*	EA	\$ 1,690.00	1	\$ 1,690.00	
Porta Potty	*	EA	\$ 325.00	2	\$ 650.00	
Sink	*	EA	\$ 357.50	2	\$ 715.00	
Wash Out	*	EA	\$ 260.00	1	\$ 260.00	
Roll Off Dumpster / 10yd	*	EA	\$ 650.00	2	\$ 1,300.00	
					\$ -	
					\$ -	
				Total	\$ 8,115.00	

*Cost listed under "Other" section need to be fully explained

Balance of Material		UOM	\$/UOM*	Value/QTY	Total/UOM	Notes
1" PVC SCH 40 with connectors		LFT	\$ 0.76	80	\$ 60.80	
1.5" PVC SCH 40 with connectors		LFT	\$ 1.05	0	\$ -	
2" PVC SCH 40 with connectors		LFT	\$ 1.65	0	\$ -	
2.5" PVC SCH 40 with connectors		LFT	\$ 2.37	0	\$ -	
4" PVC SCH 40 with connectors		LFT	\$ 4.65	340	\$ 1,581.00	
Fiber Optic		LFT	\$ 1.35	0	\$ -	
1" PVC SCH 40 elbow		EA	\$ 2.25	3	\$ 6.75	
1.5" PVC SCH 40 elbow		EA	\$ 4.89	0	\$ -	
2" PVC SCH 40 elbow		EA	\$ 17.64	0	\$ -	
2.5" PVC SCH 40 elbow		EA	\$ 17.82	0	\$ -	
4" PVC SCH 40 elbow		EA	\$ 87.17	8	\$ 697.36	
4" PVC SCH 40 Utility Sweep		EA	\$ 127.69	2	\$ 255.38	
Cat 6 cable		LFT	\$ 1.17	0	\$ -	
#12 THWN wire		LFT	\$ 0.82	0	\$ -	
1-2/C 16AWG Shielded twisted Pair		LFT	\$ 1.27	0	\$ -	
#8 THWN wire		LFT	\$ 1.41	350	\$ 493.50	
#6 THWN wire		LFT	\$ 2.22	0	\$ -	
#4 THWN wire		LFT	\$ 2.59	0	\$ -	
#2 THWN wire		LFT	\$ 3.41	410	\$ 1,398.10	
#1 THWN wire		LFT	\$ 3.98	0	\$ -	
#1/0 THWN wire		LFT	\$ 4.71	0	\$ -	
#2/0 THWN wire		LFT	\$ 5.19	0	\$ -	
#3/0 THWN wire		LFT	\$ 5.94	0	\$ -	
5/8X8' Grounding Rod with Clamp		EA	\$ 42.63	2	\$ 85.26	
#2 Landing Lug		EA	\$ 14.80	12	\$ 177.60	
Asphalt slurry coat		SQFT	\$ 0.75	0	\$ -	
Wheel Stops		EA	\$ 350.00	3	\$ 1,050.00	
Curb & Gutter		LFT	\$ 47.17	0	\$ -	
Asphalt 4" / Resurface excavations		SQFT	\$ 5.39	0	\$ -	
TOTAL BALANCE OF MATERIAL EXCLUDING LABOR; line 44					\$ 5,805.75	

ATTACHMENT C

**DETAILED PLAN FOR REPORTING ON ELIGIBLE MITIGATION ACTION
IMPLEMENTATION**

ATTACHMENT C

DETAILED PLAN FOR REPORTING ON ELIGIBLE MITIGATION ACTION IMPLEMENTATION

The Nevada Division of Environmental Protection (NDEP) will provide detailed reporting on this Volkswagen (VW) Environmental Mitigation Trust Fund for State Beneficiaries Eligible Mitigation Action project in two ways: 1, timely updates to NDEP's VW Environmental Mitigation Trust Fund webpage; and 2, Nevada's semiannual reporting obligation to Wilmington Trust (the "Trustee").

NDEP maintains a VW Environmental Mitigation Trust Fund specific webpage that has been designed to support public access and limit burden for the general public. The NDEP's VW specific webpage can currently be found at <https://ndep.nv.gov/air/vw-settlement>. Timely updates to the webpage will inform the general public on the project's status as well as when this Eligible Mitigation Action has been completed.

Subparagraph 5.3 of the Environmental Mitigation Trust Agreement for State Beneficiaries details Nevada's Reporting Obligations:

"For each Eligible Mitigation Action, no later than six months after receiving its first disbursement of Trust Assets, and thereafter no later than January 30 (for the preceding six-month period of July 1 to December 31) and July 30 (for the preceding six-month period of January 1 to June 30) of each year, each Beneficiary shall submit to the Trustee a semiannual report describing the progress implementing each Eligible Mitigation Action during the six-month period leading up to the reporting date (including a summary of all costs expended on the Eligible Mitigation Action through the reporting date). Such reports shall include a complete description of the status (including actual or projected termination date), development, implementation, and any modification of each approved Eligible Mitigation Action. Beneficiaries may group multiple Eligible Mitigation Actions and multiple sub-beneficiaries into a single report. These reports shall be signed by an official with the authority to submit the report for the Beneficiary and must contain an attestation that the information is true and correct and that the submission is made under penalty of perjury. To the extent a Beneficiary avails itself of the DERA Option described in Appendix D-2, that Beneficiary may submit its DERA Quarterly Programmatic Reports in satisfaction of its obligations under this Paragraph as to those Eligible Mitigation Actions funded through the DERA Option. The Trustee shall post each semiannual report on the State Trust's public-facing website upon receipt."

NDEP shall, in the next semiannual report following the Trustee's approval of this project, describe the progress implementing this Eligible Mitigation Action that will include a summary of all costs expended on the Eligible Mitigation Action through the reporting date. The report will also include a complete description of the status, development, implementation (including project schedule and milestone updates), and any modification to this Eligible Mitigation Action.

ATTACHMENT D

**DETAILED COST ESTIMATES FROM SELECTED OR POTENTIAL VENDORS FOR
EACH PROPOSED EXPENDITURE EXCEEDING \$25,000**

**GOE NEH Funding Opportunity April 2018
Attachment 3: Subgrant Budget Template**

PROJECT BUDGET

E. CONTRACTUAL: Contractual will cover the costs of subcontractors or subrecipients other than the Prime Applicant.

Name of subcontractor or subrecipient	Justification	Task/Mile stone 1	Task/Mile stone 2	Task/Milestone 3	Task/Miles tone 4	Task/Mile stone 5	Total Amount
Verdek LLC.			10799.5		57316.76	24067.56	\$ 92,184
							\$ -
							\$ -
							\$ -
							\$ -
							Contractual Subtotal: \$ 92,184

F. OTHER: Other costs are items required for the project which do not fit clearly into the other categories. Examples are conference fees, subscription costs, printing costs, etc.

Description	Justification	Task/Mile stone 1	Task/Mile stone 2	Task/Milestone 3	Task/Miles tone 4	Task/Mile stone 5	Total Amount
Line extention.		5000			25200		\$ 30,200
							\$ -
							\$ -
							\$ -
							\$ -
							Other Subtotal: \$ 30,200

Total Project Cost: \$ 242,702

Project Budget Summary	
	Total Request from GOE: 60,675.60
	Portion Covered by NVE: 182,026.79
	Check -> 242,702

DUAL PORT 30A AMP LEVEL 2 COMMERCIAL CHARGING STATION PEDESTAL



- DUAL PORT 30A LEVEL 2
- CHARGING PROTOCOL: SAE J-1772
- 7.2 KW PER PORT
- NEMA 3R HOUSING
- OCPP COMPLIANT
- 7" COLOR SCREEN
- UL COMPLIANT—ETL CERTIFIED
- OPTIONS
 - CABLE RETRACTOR
 - CREDIT CARD SCANNER
 - 3G/4G GPRS Modem
 - V2G per ISO 15118 (June 2018)

Model #	EVP-2002-30
Power per Port	7.2 kW (240V AC @ 30A)
Electrical Service	
Power	240/208 VAC, 30A Load with 40A Branch Circuit Per Port
Service Panel	40A Dual Breakers Per Port (No GFCI)
Service Wiring	3-wire (L1, L2, Earth Ground)
Functional Interfaces	
Connector Type	SAE J1772
Charging Protocol	SAE J1772
Standard Cable Length	>18 ft
Cable Retractor (option)	Counter Weight Overhead Retractor ADA compliant
LCD Display	1500 nits 7" color, 800 x 480, UV protected
Card Reader	ISO 14443 Type A&B, ISO 18092 NFC
Vehicle to Grid (option)	ISO 15118 (available June 2018)
Safety and Connectivity	
Ground Fault Detection	5mA CCID trip with 3 x automatic restarts
Detect Coupler Removal	Per SAE J1772™
Power Measurement	Accuracy: ± 2% from 5% to full scale (30A)
Power Report Interval	Every 15 minute on the hour
LAN (Optional)	2.4 GHz Wi-Fi (802.11 b/g/n)
Wide Area Network	3G/4G GSM, 3G/4G CDMA
Communication Protocols	OCPP 1.5, OCPP 1.6
Safety and Operation	
Enclosure Rating	NEMA 3R
Regulatory Compliance	ETL certified for USA and cUL certified for Canada; complies with UL 2594, UL 2231-1, UL 2231-2, and NEC Article 625, EMC: FCC Part 15 Class A
Surge Protection	6KV @ 3000A
Operating Temperature	-30°C to +50°C (-22°F to 122°F)
Storage Temperature	-30°C to +50°C (-22°F to 122°F)
Altitude	6000 ft
Humidity	85% non condensing

TECHNICAL PROPOSAL

ABB Terra 53 CJ

Dual-outlet 50 kW DCFC

With thousands of DCFC units deployed in around 70 countries worldwide, ABB's Terra platform is the proven, reliable solution to address EV fast charging needs for drivers at retail centers, travel stops, convenience stores, urban parking, campuses, fleets and OEM development applications. ABB's 50 kW DC Fast Charger Terra 53 CJ UL combines industry standards with fast charging technology to support all current and next generation electric vehicles, meeting all, and latest versions of CCS and CHAdeMO.



ABB Inc.
4050 E. Cotton Center Blvd
Phoenix, AZ 85040
www.abb.com/evcharging

All data and information contained herein and provided by ABB is considered confidential and proprietary, and may not be reproduced, published or distributed to, or for, any third parties without the express prior written consent of ABB. This ABB proposal is non-binding and does not constitute a contract.

Table of Contents

1	EXECUTIVE SUMMARY	3
2	SYSTEM OVERVIEW	3
2.1	TERRA INPUT POWER RATINGS (EACH UNIT):	3
2.2	STEP-UP/STEP-DOWN TRANSFORMER.....	3
2.3	AMBIENT CONDITIONS	3
2.4	ENCLOSURE	3
2.5	OUTSIDE VIEW.....	4
2.6	OPTIONS.....	4
2.7	INSTALLATION	4
3	CONTROLS, DIAGNOSTICS, & MONITORING	5
3.1	CONTROL MODES.....	5
3.2	COMMUNICATION AND CONTROL INTERFACE	5
3.3	REMOTE DIAGNOSTICS, SUPERVISION, AND PROGRAMMING.....	5
3.4	RESTART AFTER LOSS OF POWER.....	5
3.5	PROTECTION.....	5
4	COMMERCIAL PROPOSAL	6
4.1	EQUIPMENT OFFERING	6
4.2	CONNECTED SERVICES.....	6
4.3	ACTIVATION FEE (REQUIRED).....	7
4.4	WARRANTY	7
4.5	SCHEDULE OF DELIVERY	8
4.6	TERMS OF PAYMENT.....	8
4.7	TERMS OF DELIVERY.....	8
4.8	PLACING YOUR ORDER.....	8
4.9	EXCLUSIONS AND CLARIFICATIONS	8
4.10	TERMS AND CONDITIONS	8
4.11	SUPPORTING DOCUMENTS.....	9
5	ABB GENERAL TERMS AND CONDITIONS OF SALE	10

All data and information contained herein and provided by ABB is considered confidential and proprietary, and may not be reproduced, published or distributed to, or for, any third parties without the express prior written consent of ABB. This ABB proposal is non-binding and does not constitute a contract.

1 EXECUTIVE SUMMARY

This proposal is for ABB's Terra 53CJ Direct Current (DC) Fast Charger(s). Using the SAE DC fast charging standard CCS-1 (Combined Charging System) connector and CHAdeMO protocols, ABB's Terra 53 is a 50kW charger capable of charging a battery electric vehicle in 15-60 minutes depending on battery size. Compliant vehicle models driven today include the Nissan LEAF, Mitsubishi iMiEV and Outlander PHEV, BMW i3, Chevy Spark EV and Bolt, Ford Focus EV (from 2017), KIA Soul EV, VW eGolf, Hyundai IONIQ Electric, Honda Clarity EV and Jaguar iPace, as well as Tesla Models S, X and 3 with adaptor. Additionally, multiple bus and truck models are and will be CCS compliant. By implementing both CCS and CHAdeMO standards, all ABB charging systems are forward compatible with next generation BEV models.

2 SYSTEM OVERVIEW

2.1 Terra input power ratings (each unit):

- Connection voltage: 480 VAC, 3-phase, 60 Hz
- Max Input current: 75A for 50kW

2.2 Step-Up/Step-Down Transformer

ABB's EV chargers require 480V input. If the only existing power available is 208V 3-phase, a step-up transformer is required. If the only existing power available is 600V 3-phase, a step-down transformer is required. This transformer should be at least 60 kVA to handle the load of the charger. The transformer can be an isolation transformer or autotransformer.

2.3 Ambient Conditions

The equipment offered in this proposal is designed for the following ambient conditions without de-rating. Please review with ABB for applications outside these conditions:

- Operating temperature: -35° to +55 ° C
- Relative Humidity: 20% to 90%
- Max Elevation: 6560 ft (2000 m)

2.4 Enclosure

The Terra 53 are housed in a Type 3R painted stainless steel enclosure:

- System Weight: 775 lbs (350 kg)
- Dimensions: 21 W x 30 D x 75 inch H (525 x 760 x 1900 mm)
- Cable Length: 20' (6.0 m) or 12 ft (3.0 m) optional

Enclosure door should only be opened with main disconnect open. Only trained personnel may work on the Terra chargers.

All data and information contained herein and provided by ABB is considered confidential and proprietary, and may not be reproduced, published or distributed to, or for, any third parties without the express prior written consent of ABB. This ABB proposal is non-binding and does not constitute a contract.

2.5 Outside View

See cover page and/or equipment data sheets

2.6 Options

The following options are available at additional cost on Terra chargers:

- RFID - RFID reader enabled for billing transactions
- Cable Length - 20' available (12' is option)
- HMI - On-screen logo and languages can be customized
- Enclosure - Color and decals can be customized
- Credit Card Reader - Allows magnetic strip, ENV and smart phone payment
- Cable Management - field-mounted, RAL matched retraction system
- Other - Contact ABB Sales Department for additional requests

2.7 Installation

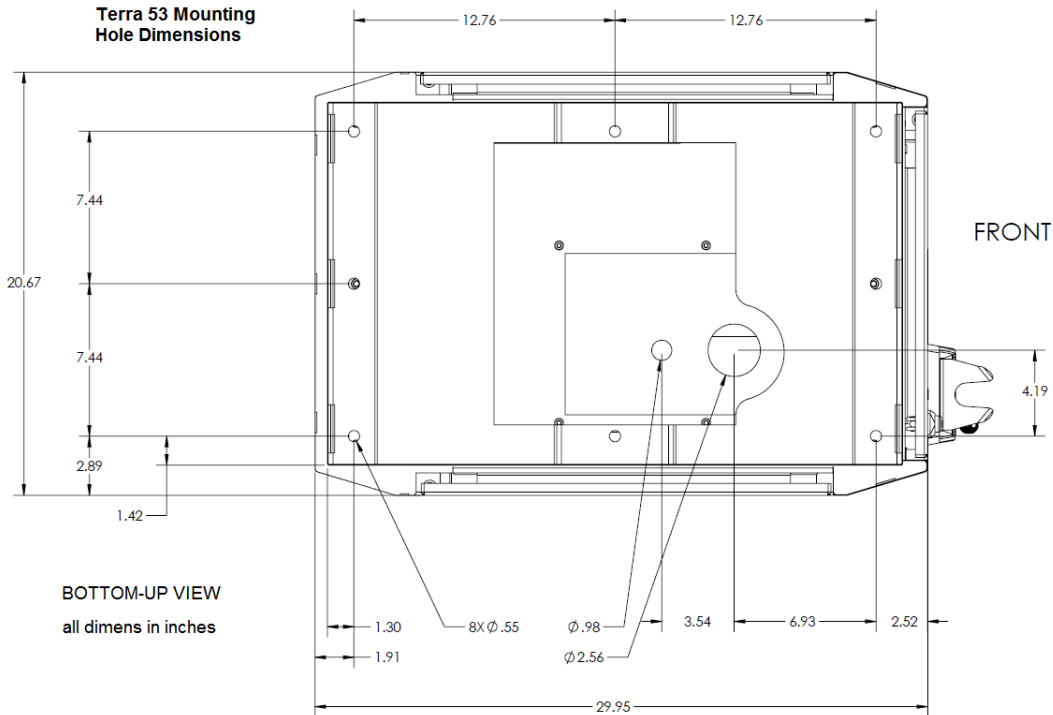

Figure 1: Terra x3 mounting-hole locations, in inches.

ABB's Terra x3 Installation Guide is provided after receipt of purchase order or special request with Non-Disclosure Agreement.

All data and information contained herein and provided by ABB is considered confidential and proprietary, and may not be reproduced, published or distributed to, or for, any third parties without the express prior written consent of ABB. This ABB proposal is non-binding and does not constitute a contract.

3 CONTROLS, DIAGNOSTICS, & MONITORING

3.1 Control Modes

The Combo protocol communicates with the EV's battery management system (BMS) to facilitate the charge.

3.2 Communication and Control Interface

The user interface for the Terra family of chargers is simple and intuitive. Each station is equipped with 3G connectivity or hard-wired Ethernet for continuous monitoring.

ABB's Terra 53 is the first UL listed & CHAdeMO 1.0 certified DC charger.

3.2.1 Local Human Machine Interface (HMI)

The Terra 53 utilizes an 8" daylight-readable touch screen for station control selections. Drivers follow on-screen instructions on how to authorize, connect, and start/stop.

3.3 Remote Diagnostics, Supervision, and Programming

During factory testing, each charger is linked to the ABB network. The internal PC is given a specific Terra number IP address, which is used for communication to ABB support and connected services charger management software packages. Each station is equipped with 3G connectivity or hard-wired Ethernet connection for continuous up-time monitoring. ABB proactively manages its charger network through an on-line, cloud-based monitoring software. An internet connection links to a station using a password-protected log-in.

3.3.1 Web portal software

ABB connected software packages are available to station owners and operators to track station usage. Various modules of the software provide statistics to break down usage details and can even assist with authorization and billing of individual user accounts. See 3-minute demo video at:

<https://www.youtube.com/watch?v=D4Uu1QVC6To>

3.4 Restart after Loss of Power

In the event of a fault, station owners can use ABB connected services software or ABB-contracted support to read error reports and reset the station remotely via Ethernet or wireless 3G network connection. Manual disconnects may also be used.

3.5 Protection

The Terra 53 is self-protecting for overcurrent, overvoltage, and ground faults.

4 COMMERCIAL PROPOSAL

4.1 Equipment Offering

- CHAdeMO and CCS-1 cables
- RFID reader (credit card reader optional)
- Low-temperature rated
- ADA Compliant
- CHAdeMO 1.0 certification
- Stainless Steel enclosure with Pure White RAL 9010 powder coat for simple customization with decals and/or labeling

4.1.1 Terra 53CJ (4EPY410108R1, 20 foot cables)

4.1.2 Credit Card reader kit (4EPY450068R1)

ABB offers an integrated Nayax credit card reader that can be field-mounted on the door of T53CJ. The Nayax credit card reader can accept payments via:

- Swipe, Contact or Contactless
- EMV Chip card reader
- NFC Contactless

An annual operating fee is also required for credit card reader functionality.

4.1.3 Cable Management Option (RTR-ABB-003K)

ABB offers a field-mounted cable management solution that keeps cable off ground during use and when connector is stored.

The retraction system is a mounted, counter weight mechanism in a vertical housing. Solution is RAL matched, easy to assemble and install.

4.2 Connected Services

4.2.1 "Driver Care" web portal (4EPY450059R1)

Enables full data reporting, analytics of charger usage, and billing; manage users via RFID or PIN, change authorization modes and direct access to ABB service network.

- Charger mapping and status
- Detailed charger fleet statistics, analytics and reports
- Access management via RFID, PIN
- Remote configuration
- Remote diagnostics, service and repair guidelines
- Case entry, escalation and notifications

All data and information contained herein and provided by ABB is considered confidential and proprietary, and may not be reproduced, published or distributed to, or for, any third parties without the express prior written consent of ABB. This ABB proposal is non-binding and does not constitute a contract.

4.2.2 Credit Card Reader Annual Operating Fee (4EPY450060R1)

The operating fee is required for credit card reader add-on.

- Pricing and reconciliation settings
- Transaction data related to charge sessions
- Access to receipts
- Financial (day) statements for accounting

4.2.3 OCPP API (4EPY450053-1)

The Open Charge Point Protocol is designed for communication between an EV charger and a central back office system. The OCPP API enables communication and control of a network of chargers. OCPP back office integration is required to support the API.

4.2.4 "Charger Connect" Connected Services (6AGC064781)

Baseline service to enable enhanced connected services (APIs and web tools).

- GSM connectivity
- Over the air software and protocol updates
- 24/7 NOC monitoring

4.3 Activation Fee (Required)

Each charger requires an Activation fee for delivery to site and administrative support.

This fee includes:

- "Charger Connect" Connected Services (6AGC064781)
 - First year included
- Remote SAT Commissioning (Project-EVCI)
 - Remote start-up support and administration to validate charger connectivity and functionality (2-hour window must be scheduled at least 3 days in advance).

4.4 Warranty

The warranty period for the Terra 53 system is offered at twenty four (24) months after initial installation, or thirty (30) months after shipment, whichever comes first. Warranty terms are as defined in the proposed project Terms and Conditions of sale which are part of this proposal (section 5).

4.4.1 Extended Warranty (Optional)

Extended Warranty beyond standard 24/30 is available for years three through five; Parts only.

All data and information contained herein and provided by ABB is considered confidential and proprietary, and may not be reproduced, published or distributed to, or for, any third parties without the express prior written consent of ABB. This ABB proposal is non-binding and does not constitute a contract.

4.5 Schedule of Delivery

Terra 53CJ is confirmed After Receipt of Order (ARO). Typical delivery to site for stocked product is currently 2 weeks.

- Packaging
 - 46.5" x 31.5" x 84.0"
 - 1,100 lbs

Please note, due to the weight of the Terra 53, delivery site should be equipped to use a crane, forklift or pallet truck for receiving and moving the unit. It should not be dropped or tilted at an angle exceeding 30°. If applicable, please specify lift gate on delivery truck when ordering.

Deliveries may be distributed in multiple deliveries.

4.6 Terms of Payment

All invoices are due Net 30 days and subject to credit approval.

Deliveries may be shipped independently.

Service invoices shall be released in full the date of on-site start-up and/or onsite commissioning services.

4.7 Terms of Delivery

Incoterms are FCA: Redlands, CA

Sales taxes: TBD

4.8 Placing your order

Purchase Orders may be submitted via email to steve.bloch@us.abb.com

4.9 Exclusions and Clarifications

- Customer will be responsible for all applicable taxes.
- Interconnecting materials not specifically listed.
- Spare parts are not included in this proposal.
- A step-up transformer is not included in this proposal.
- Any other goods and services not specifically stated in this proposal are not included.

4.10 Terms and Conditions

This offer is based on ABB's standard terms and conditions of sale, attached in section 5.

All data and information contained herein and provided by ABB is considered confidential and proprietary, and may not be reproduced, published or distributed to, or for, any third parties without the express prior written consent of ABB. This ABB proposal is non-binding and does not constitute a contract.

4.11 Supporting Documents

- [Terra 53CJ Data Sheet](#)
- [Terra Integrated Credit Card Payment Terminal Data Sheet](#)
- [DC Fast Charging Evaluator's Guide](#)
- [EV Charging Technology Fit Guide](#)
- [ABB EVI Connected Services Overview](#)
- [Why is EMC important for public charging stations?](#)

5 ABB GENERAL TERMS AND CONDITIONS OF SALE

(rev. 121218)

1. General. The terms and conditions contained herein, together with any additional or different terms contained in ABB's Proposal, if any, submitted to Purchaser (which Proposal shall control over any conflicting terms), constitute the entire agreement (the "Agreement") between the parties with respect to the order and supersede all prior communications and agreements regarding the order. Acceptance by ABB of the order, or Purchaser's acceptance of ABB's Proposal, is expressly limited to and conditioned upon Purchaser's acceptance of these terms and conditions, payment for or acceptance of any performance by ABB being acceptance. These terms and conditions may not be changed or superseded by any different or additional terms and conditions proposed by Purchaser to which terms ABB hereby objects. Unless the context otherwise requires, the term "Equipment" as used herein means all of the equipment, parts, accessories sold, and all software and software documentation, if any, licensed to Purchaser by ABB ("Software") under the order. Unless the context otherwise requires, the term "Services" as used herein means all labor, supervisory, technical and engineering, installation, repair, consulting or other services provided by ABB under the order. As used herein, the term "Purchaser" shall include the initial end user of the Equipment and/or services; provided, however, that Paragraph 13(a) shall apply exclusively to the initial end user.

2. Prices.

- (a) Unless otherwise specified in writing, all Proposals expire thirty (30) days from the date thereof.
- (b) Unless otherwise stated herein, Services prices are based on normal business hours (8 a.m. to 5 p.m. Monday through Friday). Overtime and Saturday hours will be billed at one and one-half (1 1/2) times the hourly rate; and Sunday hours will be billed at two (2) times the hourly rate; holiday hours will be billed at three (3) times the hourly rate. If a Services rate sheet is attached hereto, the applicable Services rates shall be those set forth in the rate sheet. Rates are subject to change without notice.
- (c) The price does not include any federal, state or local property, license, privilege, sales, use, excise, gross receipts, or other like taxes which may now or hereafter be applicable. Purchaser agrees to pay or reimburse any such taxes which ABB or its suppliers are required to pay or collect. If Purchaser is exempt from the payment of any tax or holds a direct payment permit, Purchaser shall, upon order placement, provide ABB a copy, acceptable to the relevant governmental authorities of any such certificate or permit.
- (d) The price includes customs duties and other importation or exportation fees, if any, at the rates in effect on the date of ABB's Proposal. Any change after that date in such duties, fees, or rates, shall increase the price by ABB's additional cost.

3. Payment.

- (a) Unless specified to the contrary in writing by ABB, payment terms are net cash, payable without offset, in United States Dollars, 30 days from date of invoice by wire transfer to the account designated by ABB in the Proposal.
- (b) If in the judgment of ABB, the financial condition of Purchaser at any time prior to delivery does not justify the terms of payment specified, ABB may require payment in advance, payment security satisfactory to ABB, or may terminate the order, whereupon ABB shall be entitled to receive reasonable cancellation charges. If delivery is delayed by Purchaser, payment shall be due on the date ABB is prepared to make delivery. Delays in delivery or nonconformities in any installments delivered shall not relieve Purchaser of its obligation to accept and pay for remaining installments.
- (c) Purchaser shall pay, in addition to the overdue payment, a late charge equal to the lesser of 1 1/2% per month or any part thereof or the highest applicable rate allowed by law on all such overdue amounts plus ABB's attorneys' fees and court costs incurred in connection with collection.

4. Changes.

- (a) Any changes requested by Purchaser affecting the ordered scope of work must be accepted by ABB and resulting adjustments to affected provisions, including price, schedule, and guarantees mutually agreed in writing prior to implementation of the change.
- (b) ABB may, at its expense, make such changes in the Equipment or Services as it deems necessary, in its sole discretion, to conform the Equipment or Services to the applicable specifications. If Purchaser objects to any such changes, ABB shall be relieved of its obligation to conform to the applicable specifications to the extent that conformance may be affected by such objection.

5. Delivery.

- (a) All Equipment manufactured, assembled or warehoused in the continental United States is delivered F.O.B. point of shipment. Equipment shipped from outside the continental United States is delivered F.O.B. United States port of entry. Purchaser shall be responsible for any and all demurrage or detention charges.
- (b) If the scheduled delivery of Equipment is delayed by Purchaser or by Force Majeure, ABB may move the Equipment to storage for the account of and at the risk of Purchaser whereupon it shall be deemed to be delivered.
- (c) Shipping and delivery dates are contingent upon Purchaser's timely approvals and delivery by Purchaser of any documentation required for ABB's performance hereunder.
- (d) Claims for shortages or other errors in delivery must be made in writing to ABB within ten days of delivery. Equipment may not be returned except with the prior written consent of and subject to terms specified by ABB. Claims for damage after delivery shall be made directly by Purchaser with the common carrier.

6. Title & Risk of Loss. Except with respect to Software (for which title shall not pass, use being licensed) title to Equipment shall remain in ABB until fully paid for. Notwithstanding any agreement with respect to delivery terms or payment of transportation charges, risk of loss or damage shall pass to Purchaser upon delivery.

7. Inspection, Testing and Acceptance.

- (a) Any inspection by Purchaser of Equipment on ABB's premises shall be scheduled in advance to be performed during normal working hours.
- (b) If the order provides for factory acceptance testing, ABB shall notify Purchaser when ABB will conduct such testing prior to shipment. Unless Purchaser states specific objections in writing within ten (10) days after completion of factory acceptance testing, completion of the acceptance test constitutes Purchaser's factory acceptance of the Equipment and its authorization for shipment.
- (c) If the order provides for site acceptance testing, testing will be performed by ABB personnel to verify that the Equipment has arrived at site complete, without physical damage, and in good operating condition. Completion of site acceptance testing constitutes full and final acceptance of the Equipment. If, through no fault of ABB, acceptance testing is not completed within thirty (30) days after arrival of the Equipment at the site, the site acceptance test shall be deemed completed and the Equipment shall be deemed accepted.

All data and information contained herein and provided by ABB is considered confidential and proprietary, and may not be reproduced, published or distributed to, or for, any third parties without the express prior written consent of ABB. This ABB proposal is non-binding and does not constitute a contract.

8. Warranties and Remedies.

(a) Equipment and Services Warranty. ABB warrants that Equipment (excluding Software, which is warranted as specified in paragraph (d) below) shall be delivered free of defects in material and workmanship and that Services shall be free of defects in workmanship. The Warranty Remedy Period for Equipment (excluding Software, Spare Parts and Refurbished or Repaired Parts) shall end twelve (12) months after installation or eighteen (18) months after date of shipment, whichever first occurs. The Warranty Remedy Period for new spare parts shall end twelve (12) months after date of shipment. The Warranty Remedy Period for refurbished or repaired parts shall end ninety (90) days after date of shipment. The Warranty Remedy Period for Services shall end ninety (90) days after the date of completion of Services.

(b) Equipment and Services Remedy. If a nonconformity to the foregoing warranty is discovered in the Equipment or Services during the applicable Warranty Remedy Period, as specified above, under normal and proper use and provided the Equipment has been properly stored, installed, operated and maintained and written notice of such nonconformity is provided to ABB promptly after such discovery and within the applicable Warranty Remedy Period, ABB shall, at its option, either (i) repair or replace the nonconforming portion of the Equipment or re-perform the nonconforming Services or (ii) refund the portion of the price applicable to the nonconforming portion of Equipment or Services. If any portion of the Equipment or Services so repaired, replaced or re-performed fails to conform to the foregoing warranty, and written notice of such nonconformity is provided to ABB promptly after discovery and within the original Warranty Remedy Period applicable to such Equipment or Services or 30 days from completion of such repair, replacement or re-performance, whichever is later, ABB will repair or replace such nonconforming Equipment or re-perform the nonconforming Services. The original Warranty Remedy Period shall not otherwise be extended.

(c) Exceptions. ABB shall not be responsible for providing working access to the nonconforming Equipment, including disassembly and re-assembly of non-ABB supplied equipment, or for providing transportation to or from any repair facility, all of which shall be at Purchaser's risk and expense. ABB shall have no obligation hereunder with respect to any Equipment which (i) has been improperly repaired or altered; (ii) has been subjected to misuse, negligence or accident; (iii) has been used in a manner contrary to ABB's instructions; (iv) is comprised of materials provided by or a design specified by Purchaser; or (v) has failed as a result of ordinary wear and tear. Equipment supplied by ABB but manufactured by others is warranted only to the extent of the manufacturer's warranty, and only the remedies, if any, provided by the manufacturer will be allowed.

(d) Software Warranty and Remedies. ABB warrants that, except as specified below, the Software will, when properly installed, execute in accordance with ABB's published specification. If a nonconformity to the foregoing warranty is discovered during the period ending one (1) year after the date of shipment and written notice of such nonconformity is provided to ABB promptly after such discovery and within that period, including a description of the nonconformity and complete information about the manner of its discovery, ABB shall correct the nonconformity by, at its option, either (i) modifying or making available to the Purchaser instructions for modifying the Software; or (ii) making available at ABB's facility necessary corrected or replacement programs. ABB shall have no obligation with respect to any nonconformities resulting from (i) unauthorized modification of the Software or (ii) Purchaser-supplied software or interfacing. ABB does not warrant that the functions contained in the software will operate in combinations which may be selected for use by the Purchaser, or that the software products are free from errors in the nature of what is commonly categorized by the computer industry as "bugs".

(e) THE FOREGOING WARRANTIES ARE EXCLUSIVE AND IN LIEU OF ALL OTHER WARRANTIES OF QUALITY AND PERFORMANCE, WHETHER WRITTEN, ORAL OR IMPLIED, AND ALL OTHER WARRANTIES INCLUDING ANY IMPLIED WARRANTIES OF MERCHANTABILITY OR FITNESS FOR A PARTICULAR PURPOSE OR USAGE OF TRADE ARE HEREBY DISCLAIMED. THE REMEDIES STATED HEREIN CONSTITUTE PURCHASER'S EXCLUSIVE REMEDIES AND ABB'S ENTIRE LIABILITY FOR ANY BREACH OF WARRANTY.

9. Patent Indemnity.

(a) ABB shall defend at its own expense any action brought against Purchaser alleging that the Equipment or the use of the Equipment to practice any process for which such Equipment is specified by ABB (a "Process") directly infringes any claim of a patent of the United States of America and to pay all damages and costs finally awarded in any such action, provided that Purchaser has given ABB prompt written notice of such action, all necessary assistance in the defense thereof and the right to control all aspects of the defense thereof including the right to settle or otherwise terminate such action in behalf of Purchaser.

(b) ABB shall have no obligation hereunder and this provision shall not apply to: (i) any other equipment or processes, including Equipment or Processes which have been modified or combined with other equipment or process not supplied by ABB; (ii) any Equipment or Process supplied according to a design, other than an ABB design, required by Purchaser; (iii) any products manufactured by the Equipment or Process; (iv) any patent issued after the date hereof; or (v) any action settled or otherwise terminated without the prior written consent of ABB.

(c) If, in any such action, the Equipment is held to constitute an infringement, or the practice of any Process using the Equipment is finally enjoined, ABB shall, at its option and its own expense, procure for Purchaser the right to continue using said Equipment; or modify or replace it with non-infringing equipment or, with Purchaser's assistance, modify the Process so that it becomes non-infringing; or remove it and refund the portion of the price allocable to the infringing Equipment. THE FOREGOING PARAGRAPHS STATE THE ENTIRE LIABILITY OF ABB AND EQUIPMENT MANUFACTURER FOR ANY PATENT INFRINGEMENT.

(d) To the extent that said Equipment or any part thereof is modified by Purchaser, or combined by Purchaser with equipment or processes not furnished hereunder (except to the extent that ABB is a contributory infringer) or said Equipment or any part thereof is used by Purchaser to perform a process not furnished hereunder by ABB or to produce an article, and by reason of said modification, combination, performance or production, an action is brought against ABB, Purchaser shall defend and indemnify ABB in the same manner and to the same extent that ABB would be obligated to indemnify Purchaser under this "Patent Indemnity" provision. **10. Limitation of Liability.**

(a) In no event shall ABB, its suppliers or subcontractors be liable for special, indirect, incidental or consequential damages, whether in contract, warranty, tort, negligence, strict liability or otherwise, including, but not limited to, loss of profits or revenue, loss of use of the Equipment or any associated equipment, cost of capital, cost of substitute equipment, facilities or services, downtime costs, delays, and claims of customers of the Purchaser or other third parties for any damages. ABB's liability for any claim whether in contract, warranty, tort, negligence, strict liability, or otherwise for any loss or damage arising out of, connected with, or resulting from this Agreement or the performance or breach thereof, or from the design, manufacture, sale, delivery, resale, repair, replacement, installation, technical direction of installation, inspection, operation or use of any equipment covered by or furnished under this Agreement, or from any services rendered in connection therewith, shall in no case (except as provided in the section entitled "Patent Indemnity") exceed one-half (1/2) of the purchase price allocable to the Equipment or part thereof or Services which gives rise to the claim.

(b) All causes of action against ABB arising out of or relating to this Agreement or the performance or breach hereof shall expire unless brought within one year of the time of accrual thereof.

(c) In no event, regardless of cause, shall ABB be liable for penalties or penalty clauses of any description or for indemnification of Purchaser or others for costs, damages, or expenses arising out of or related to the Equipment and Services.

11. Laws and Regulations. ABB does not assume any responsibility for compliance with federal, state or local laws and regulations, except as expressly set forth herein, and compliance with any laws and regulations relating to the operation or use of the Equipment or Software is the sole responsibility of the Purchaser. All laws and regulations referenced herein shall be those in effect as of the Proposal date. In the event of any subsequent revisions or changes thereto, ABB assumes no responsibility for compliance therewith. If Purchaser desires a modification as a result of any such change or revision, it shall be treated as a change

All data and information contained herein and provided by ABB is considered confidential and proprietary, and may not be reproduced, published or distributed to, or for, any third parties without the express prior written consent of ABB. This ABB proposal is non-binding and does not constitute a contract.

per Article 4. Nothing contained herein shall be construed as imposing responsibility or liability upon ABB for obtaining any permits, licenses or approvals from any agency required in connection with the supply, erection or operation of the Equipment. This Agreement shall be governed by the laws of the State of New York, but excluding the provisions of the United Nations Convention on Contracts for the International Sale of Goods and excluding New York law with respect to conflicts of law. Purchaser agrees that all causes of action against ABB under this Agreement shall be brought in the State Courts of the State of New York, or the U.S. District Court for the Southern District of New York. If any provision hereof, partly or completely, shall be held invalid or unenforceable, such invalidity or unenforceability shall not affect any other provision or portion hereof and these terms shall be construed as if such invalid or unenforceable provision or portion thereof had never existed.

12. OSHA. ABB warrants that the Equipment will comply with the relevant standards of the Occupational Safety and Health Act of 1970 ("OSHA") and the regulations promulgated thereunder as of the date of the Proposal. Upon prompt written notice from the Purchaser of a breach of this warranty, ABB will replace the affected part or modify it so that it conforms to such standard or regulation. ABB's obligation shall be limited to such replacement or modification. In no event shall ABB be responsible for liability arising out of the violation of any OSHA standards relating to or caused by Purchaser's design, location, operation, or maintenance of the Equipment, its use in association with other equipment of Purchaser, or the alteration of the Equipment by any party other than ABB.

13. Software License.

(a) ABB owns all rights in or has the right to sublicense all of the Software, if any, to be delivered to Purchaser under this Agreement. As part of the sale made hereunder Purchaser hereby obtains a limited license to use the Software, subject to the following: (i) The Software may be used only in conjunction with equipment specified by ABB; (ii) The Software shall be kept strictly confidential; (iii) The Software shall not be copied, reverse engineered, or modified; (iv) The Purchaser's right to use the Software shall terminate immediately when the specified equipment is no longer used by the Purchaser or when otherwise terminated, e.g. for breach, hereunder; and (v) the rights to use the Software are non-exclusive and non-transferable, except with ABB's prior written consent.

(b) Nothing in this Agreement shall be deemed to convey to Purchaser any title to or ownership in the Software or the intellectual property contained therein in whole or in part, nor to designate the Software a "work made for hire" under the Copyright Act, nor to confer upon any person who is not a named party to this Agreement any right or remedy under or by reason of this Agreement. In the event of termination of this License, Purchaser shall immediately cease using the Software and, without retaining any copies, notes or excerpts thereof, return to ABB the Software and all copies thereof and shall remove all machine-readable Software from all of Purchaser's storage media.

14. Inventions and Information. Unless otherwise agreed in writing by ABB and Purchaser, all right, title and interest in any inventions, developments, improvements or modifications of or for Equipment and Services shall remain with ABB. Any design, manufacturing drawings or other information submitted to the Purchaser remains the exclusive property of ABB. Purchaser shall not, without ABB's prior written consent, copy or disclose such information to a third party. Such information shall be used solely for the operation or maintenance of the Equipment and not for any other purpose, including the duplication thereof in whole or in part.

15. Force Majeure. ABB shall neither be liable for loss, damage, detention or delay nor be deemed to be in default for failure to perform when prevented from doing so by causes beyond its reasonable control including but not limited to acts of war (declared or undeclared), Acts of God, fire, strike, labor difficulties, acts or omissions of any governmental authority or of Purchaser, compliance with government regulations, insurrection or riot, embargo, delays or shortages in transportation or inability to obtain necessary labor, materials, or manufacturing facilities from usual sources or from defects or delays in the performance of its suppliers or subcontractors due to any of the foregoing enumerated causes. In the event of delay due to any such cause, the date of delivery will be extended by period equal to the delay plus a reasonable time to resume production, and the price will be adjusted to compensate ABB for such delay.

16. Cancellation. Any order may be cancelled by Purchaser only upon prior written notice and payment of termination charges, including but not limited to, all costs identified to the order incurred prior to the effective date of notice of termination and all expenses incurred by ABB attributable to the termination, plus a fixed sum of ten (10) percent of the final total price to compensate for disruption in scheduling, planned production and other indirect costs.

17. Termination. No termination by Purchaser for default shall be effective unless, within fifteen (15) days after receipt by ABB of Purchaser's written notice specifying such default, ABB shall have failed to initiate and pursue with due diligence correction of such specified default.

18. Export Control.

(a) Purchaser represents and warrants that the Equipment and Services provided hereunder and the "direct product" thereof are intended for civil use only and will not be used, directly or indirectly, for the production of chemical or biological weapons or of precursor chemicals for such weapons, or for any direct or indirect nuclear end use. Purchaser agrees not to disclose, use, export or re-export, directly or indirectly, any information provided by ABB or the "direct product" thereof as defined in the Export Control Regulations of the United States Department of Commerce, except in compliance with such Regulations.

(b) If applicable, ABB shall file for a U.S. export license, but only after appropriate documentation for the license application has been provided by Purchaser. Purchaser shall furnish such documentation within a reasonable time after order acceptance. Any delay in obtaining such license shall suspend performance of this Agreement by ABB. If an export license is not granted or, if once granted, is thereafter revoked or modified by the appropriate authorities, this Agreement may be canceled by ABB without liability for damages of any kind resulting from such cancellation. At ABB's request, Purchaser shall provide to ABB a Letter of Assurance and End-User Statement in a form reasonably satisfactory to ABB.

(c) Client agrees to adhere to all applicable import and export control laws, regulations, orders and requirements, including but not limited to those of the United States and the jurisdictions to or through which the purchased goods are transported.

(d) With respect to orders that have been accepted by ABB but not delivered, ABB commits (i) to full transparency in regard to the cost increases associated with any legislation or tariffs; and (ii) that any increases resulting from changes in legislation or tariffs will solely reflect the additional costs incurred as a result of legislation or tariffs and will not include any additional overhead costs or profits.

19. Assignment. Any assignment of this Agreement or of any rights or obligations under the Agreement without prior written consent of ABB shall be void.

20. Nuclear Insurance – Indemnity. For applications in nuclear projects, the Purchaser and/or its end user customer shall have complete insurance protection against liability and property damage resulting from a nuclear incident to and shall indemnify ABB, its subcontractors, suppliers and vendors against all claims resulting from a nuclear incident.

21. Resale. If Purchaser resells any of the Equipment, the sale terms shall limit ABB's liability to the buyer to the same extent that ABB's liability to Purchaser is limited hereunder.

22. Entire Agreement. This Agreement constitutes the entire agreement between ABB and Purchaser. There are no agreements, understandings, restrictions, warranties, or representations between ABB and Purchaser other than those set forth herein or herein provided.

All data and information contained herein and provided by ABB is considered confidential and proprietary, and may not be reproduced, published or distributed to, or for, any third parties without the express prior written consent of ABB. This ABB proposal is non-binding and does not constitute a contract.

Electric Vehicle Infrastructure

Integrated credit card payment terminal



Any ABB Terra charging system can be equipped with an integrated payment terminal to facilitate payment by credit card and NFC. A payment terminal enables paid charging without a membership model and can operate with or without a back office.

— ABB's certified and secure payment terminal is integrated with the charging station's intelligence.

Business model choice

Whether you are operating a network of chargers or want a way to monetize your infrastructure investment, ABB offers an integrated payment terminal solution. This payment terminal supports payment via credit card and Near Field Communication (NFC).

The payment terminal is available as a field upgrade for any charger from the Terra series of fast and high power charging systems. The default RFID and OCPP functionality of the charger can also be maintained to enable multiple methods of consumer payment interaction.

Commercial enablement

The integrated credit card payment terminal option requires a one-time investment in hardware and installation. The recurring costs consist of the annual fee for the web tool which provides operational control, and the transaction costs of the acquirer. ABB's credit card-based payment solutions support various acquirers for the financial processing of the transactions.

Applications

- Public infrastructure roaming enablement
- Large commercial charging networks
- Projects requiring credit card readers
- Charging networks without back office
- Charging networks without membership model

Main features

- Payment via credit card and NFC
- Payment upfront per charging session
- Support of low value transactions
- High res touch screen displays pricing information
- Automatic cancellation of payment in case of error during the first minutes of charging
- Can work in parallel with RFID and OCPP network functionality
- Easy field upgrade for any ABB Terra system
- Remote software updates

Operator control with ABB web tools

- Allows price setting based on session, time and kWh
- Set minimum and maximum fees
- Set auto stop when max fee is reached
- Show final charge on HMI interface
- Transaction overview
- Access to receipts and reconciliation data

General specifications	
Accepted payments	EMV contact chip without PIN entry; NFC with smartphone, contactless cards or stickers
EMV Payment schemes	Visa™, MasterCard™
NFC / Contactless Payment schemes	MasterCard PayPass™, Visa payWave™
Payment service provider	Nayax
Supported chargers	ABB Terra charging stations
Field upgradable	Yes
Compliance & Safety	CSA and UL, ESD protected Compatible with EU disclosure regulations ISO 7811 Magnetic Stripe Card ISO 7816 Contact Smart Card ISO 14443 Contactless Type A and B ISO 15693 NFC
Certificates	EMVCo L1 contactless type approval, EMVCo L1 contact type approval, PayPass™, payWave™ compatible
Chip card reader	ISO 7816, EMV 2000 Level 1
User interface	Color Touch LCD Display 2.4 inch IPS 320 x 240 + 4 LEDs + Buzzer + Speaker + Six Soft Touch Buttons
Dimensions (H x W x H)	4.13" x 3.31" x 1.9" 105mm x 84mm x 48.3mm
Weight	8.11 ounces / 230 grams
Operating Conditions	Temperature -30°C - 50°C (-22°F - 122°F) Humidity 25% - 95% (non-condensing)
Management	Remote software updates
Language	Two language display capability
Security	High Security Encryption System: AES/DES Anti-Vandal with Gorilla Glass Shock and tilt detector

Payment terminal dimensions

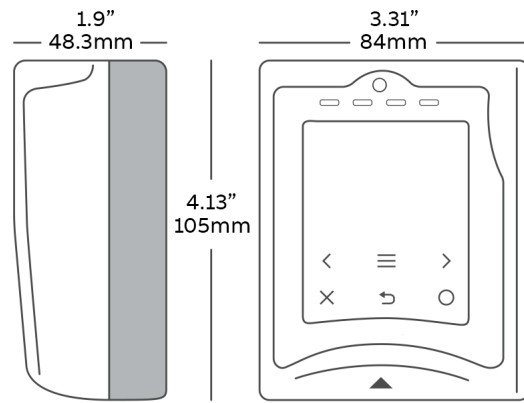

ABB Inc.
4050 E. Cotton Center Blvd
Phoenix, AZ 85040
United States
Phone: 800-435-7365
E-mail: US-evci@us.abb.com

ABB Inc.
800 Hymus Boulevard
Saint-Laurent, QC H4S 0B5
Canada
Phone: 800-435-7365
E-mail: CA-evci@abb.com

We reserve the right to make technical changes or modify the contents of this document without prior notice. We reserve all rights in this document and in the subject matter and illustrations contained therein. Any reproduction, disclosure to third parties or utilization of its contents – in whole or in parts – is forbidden without prior written consent of ABB. Copyright© 2018 ABB. All rights reserved.